

Troubleshooting Guide

1. Introduction

Performance of a load cell force (or weigh) measurement system is dependent upon the integrity of the physical installation, correct interconnection of the components, proper performance of the basic components which make up the system, and calibration of the system. Presuming that the installation was originally operating and was calibrated, troubleshooting can begin by checking the components individually to determine if they have been damaged or have failed.

The basic components are:

- Load cells
- Mechanical supports and load connections
- Interconnecting cables
- Junction boxes
- Signal conditioning electronics

1.1. Mechanical Installation

Load Cells which are not mounted in accordance with the manufacturer's recommendations may not perform to manufacturer's specifications. It is always worthwhile to check:

- Mounting surfaces for cleanliness, flatness, and alignment
- Torque of all mounting hardware
- Load cell orientation: "Dead" end on mechanical reference or load forcing source, "live" end connected to the load to be measured. (Dead end is the end closest mechanically to the cable exit or connector.)

Proper hardware (thread sizes, jam nuts, swivels, etc) as required to connect the load to the load cell. A fundamental requirement is that there be one, and only one load path! This load path must be through the load axis of the load cell. This may sound elementary, however it is a commonly overlooked problem.

1.2. Electrical Installation

Proper load cell performance is also dependent upon the electrical "system." The following items are common problem areas:

- Loose or dirty electrical connections, or incorrect connection of color coded wires.
- Failure to make use of remote sensing of excitation voltage on long cables.
- Incorrect setting of excitation voltage. (The best setting is 10 VDC, because that voltage is used to calibrate the load cell in the factory. The maximum voltage allowed is 15 or 20 volts, depending on the model. Some battery-operated signal conditioners use smaller voltages, down to 1.25 volts, to conserve battery power.)
- Loading of the bridge circuit. (Highly accurate load cell systems require highly accurate read-out instruments. Such instruments typically have very high input impedances to avoid circuit loading errors.)

2. Load Cell Evaluations

It is quite easy to make a quick diagnostic check of a load cell. The procedure is quite simple and a minimum of equipment is required. Should it be determined that the load cell is at fault, the unit should be returned to the factory for further evaluation and repair as may be required. Many of the checks may be performed with an ohmmeter.

2.1. Check Bridge Circuitry And Zero Balance

(Numbers apply to standard 350 ohm bridges.)

- Instrument required: Ohmmeter with 0.1 ohms resolution in the range of 250-400 ohms.
- Bridge Input Resistance: RAD should be 350 ± 3.5 ohms (unless the cell has "standardized output," in which case the resistance should be less than 390 ohms)
- Bridge Output Resistance: RBC should be 350 ± 3.5 ohms
- Bridge Leg Resistances: Comparing the leg resistances at no load permits evaluation of the cause of any permanent damage in the load cell flexure. The "computed unbalance" of the bridge shows the general

condition of the cell.

- The computed unbalance, in units of “mV/V,” is determined as follows: $\text{Unbalance} = 1.4 \cdot (\text{RAC} - \text{RAB} + \text{RBD} - \text{RCD})$
- The Zero Offset, in units of “% of Rated Output”, is determined as follows: $\text{Zero Offset} = 100 \cdot \text{Unbalance} \div \text{Rated Output}$

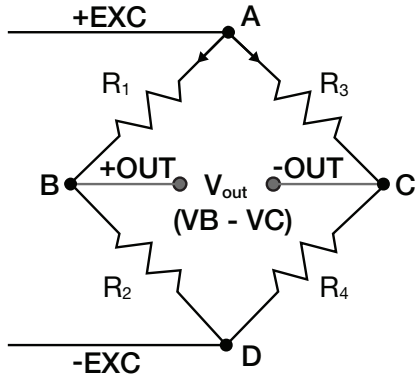

MEASURE AND RECORD

BRIDGE INPUT RESISTANCE	RAD = _____
BRIDGE OUTPUT RESISTANCE	RBC = _____
BRIDGE LEG RESISTANCE	RAC = _____
	RAB = _____
	RBD = _____
	RCD = _____

If the ohmmeter resolution is 0.1 ohm or better, then a computed Zero Offset of greater than 20 percent is a clear indication of overload. A computed zero balance of 10-20% is an indication of probable overload. If the load cell has been overloaded, mechanical damage has been done that is not repairable, because overloading results in permanent deformation within the flexural element and gages, destroying the carefully balanced processing that results in performance to Interface specifications. While it is possible to electrically re-zero a load cell following overload, it is not recommended because this does nothing to restore the affected performance parameters or the degradation to structural integrity.

If the degree of overload is not severe the cell may in some cases be used at the user’s discretion, although some performance parameters may violate specifications and the cyclic life of the load cell may be reduced.

2.2. Insulation Resistance Tests

- Insulation resistance, shield to conductors: Connect all the conductors together, and measure the resistance between all those wires and the shield in the cable.
- Insulation resistance, load cell flexure to conductors: Connect all the conductors together, and measure the resistance between all those wires and the metal body of the load cell.

The tests described above can be performed using a standard ohm meter, although best results are obtained with a megohm meter. If resistance is beyond the standard ohmmeter range, about 10 megohms, the cell is probably OK. However, some kinds of electrical shorts show up only when using a megohm meter or with voltages higher than most ohmmeters can supply.

CAUTION:

Never Use A Voltage Higher Than 50 VDC Or 35 VRMS AC To Measure Insulation Resistance, Or Breakdown Of The Insulation Between The Gages And The Flexure May Result. Low Resistance (Below 5000 Megohms) Is Often Caused By Moisture Or Pinched Wires. The Cause And Extent Of Damage Must Be Established At The Factory To Determine If The Load Cell May Be Salvaged.

3. Factory Evaluation

If the load cell is defective for reasons other than overload, return to factory for detailed evaluation. Factory evaluation may show that the cell is repairable or non-repairable and if repair or replacement will be under warranty. If non-warranty, the customer will be contacted with the cost of repairs and recalibration, and a delivery date after receipt of authorization to proceed.