

# interface

FORCE MEASUREMENT SOLUTIONS.

# TORQUE MEASUREMENT PRIMER

## THE TWO TYPES OF TORQUE TRANSDUCERS

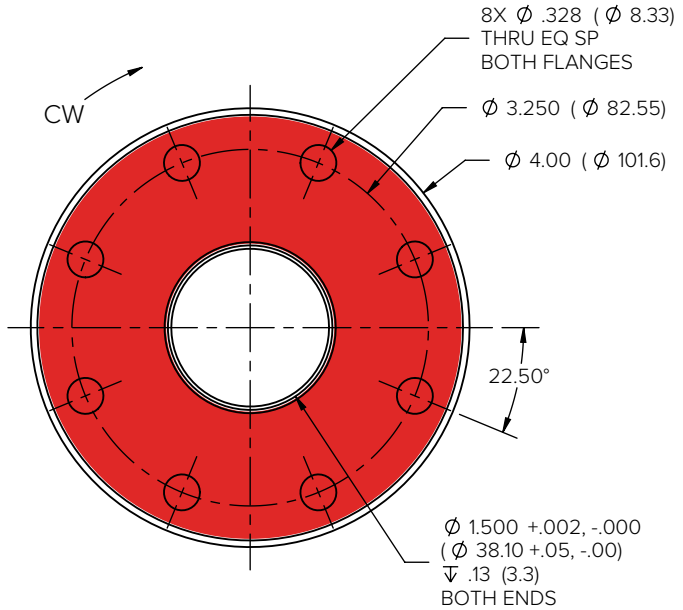

©1998–2009 Interface Inc.

Revised 2024

All rights reserved.

*Interface, Inc. makes no warranty, either expressed or implied, including, but not limited to, any implied warranties of merchantability or fitness for a particular purpose, regarding these materials, and makes such materials available solely on an “as-is” basis.*

*In no event shall Interface, Inc. be liable to anyone for special, collateral, incidental, or consequential damages in connection with or arising out of use of these materials.*

Interface<sup>®</sup>, Inc.

7401 Butherus Drive

Scottsdale, Arizona 85260

480.948.5555 phone

[contact@interfaceforce.com](mailto:contact@interfaceforce.com)

<http://www.interfaceforce.com>

Interface offers this primer as a resource to help you choose the most suitable torque transducer. With a wide variety of transducers available, reviewing this guide can aid you in making an informed decision based on your specific use case requirements.

Contributor Keith Skidmore, a measurement expert and engineer, emphasizes the importance of selecting the right capacity for your torque transducer.

The primer outlines the two main categories of torque transducers: rotary and reaction. You can delve into the details of exactly how torque transducers function, with technical explanations about configurations, strain gages, output voltage and transmitting power and signal. It covers slip rings, transformers, and electronics.

By design torque transducers come in two primary mechanical configurations: shaft and flange styles. Understand the advantages to each style in this guide.

Find a step-by-step process for selecting the proper capacity, considering factors of average running torque, load service factors and drive service factors. By considering these factors and multiplying the average running torque by the combined service factor, you can determine the maximum expected peak torque, which helps you choose a transducer with adequate capacity.

Following capacity selection, accuracy and resolution become essential considerations. Torque transducer accuracy is typically specified as a percentage of its capacity. Resolution, on the other hand, is influenced by the signal type.

Environmental factors, including temperature, moisture, and dust, must also be considered. Learn about the specifications for storage, operating, and compensated temperature ranges.

The primer also covers the importance of couplings and mounting, two critical topics that will impact accuracy and performance.

By understanding the various aspects covered in this comprehensive guide, you will be well-equipped to choose the most suitable torque transducer for your specific needs and applications.

Start exploring and be sure to consult Interface Application Engineers if you have questions. As well, use the online Interface Torque Selection Guide to narrow down the best torque transducer for your specific requirements.

## **TABLE OF CONTENTS**

|  |   |
|--|---|
| The Two Types of Torque Transducers .....  | 1 |
| Rotary and Reaction.....                   | 1 |
| Choosing the Right Torque Transducer ..... | 2 |
| Shaft or Flange Style?.....                | 5 |
| Installation Methods .....                 | 7 |

# THE TWO TYPES OF TORQUE TRANSDUCERS

The following primer is a resource to use in selecting a torque transducer for your next project or to put in a test lab. The options are plentiful, so reviewing this guide can help you make the best decision based on your specific use case and requirements.

To start, there are two basic types of torque transducers: rotary and reaction.

## ROTARY AND REACTION

---

**A reaction or static torque transducer** measures torque without rotating, while a rotary torque transducer rotates as part of the system. A rotary sensor is merely a reaction sensor that is allowed to rotate.

Normally, a reaction style sensor has a cable attached to it to supply excitation voltage to the strain gage bridge and for output of the mV/V signal. The spinning of these sensors is prevented by the attached cable. To get around the issue of the attached cable, a variety of methods have been used for rotary sensors. Some of those methods include slip rings, rotary transformers, rotating electronics, rotating digital electronics and radio telemetry.

Like a load cell, a torque transducer consists of a metal spring element or flexure. Strain gages are applied to the flexure in a Wheatstone bridge configuration. Torque applied to the sensor causes bending or shear strain in the gaged area, generating an output voltage signal proportional to torque.

Slip rings are among the original methods used for power and signal transfer. The rotating sensor has a set of metal rings pressed onto its shaft. Each corner of the strain gage bridge is connected to a ring. Carbon silver brushes slide on the rings, transferring power and signal. Slip ring sensors are usually not recommended for continuous or high RPM use because of wear in the brushes, which causes dust and creates noise in the signal. Slip-ring sensors require periodic cleaning and brush replacement. An advantage of slip-ring style sensors is they can be used with traditional mV/V instrumentation.

Another commonly used method involves rotary transformers. This

method uses a set of transformers, one to carry the excitation voltage onto the shaft and the other to transfer the signal off. They are called rotary transformers because one winding of each transformer rotates relative to the other winding. Advantages of this approach include low noise and no wearing parts in the electrical path. Because of the AC nature of transformers, AC carrier amplifiers are required for signal conditioning. Some rotary transformer torque transducers include built-in signal conditioning, allowing for a standard DC supply voltage and a high-level signal output.

The next type of rotary torque transducer adds electronics to the rotating shaft. Unlike rotary transformer sensors, these types have strain gage amplifiers and signal converters directly on the rotating shaft. Power is still transferred inductively, but unlike rotary transformer sensors, shaft electronics condition and rectify the supply voltage, amplify the bridge output signal and convert the signal for inductive transfer back to the stator. In a simple case, the signal is converted and transferred as a frequency and then converted from frequency to DC voltage output in the stator electronics. An advantage of this approach is lower manufacturing cost since precisely wound and aligned transformers are not required.

A more complex approach involves digitization of the torque signal on the rotor. This approach adds an A/D converter, digital signal transfer across the inductive coupling, and D/A conversion in the stator. Advantages of this approach include the ability to switch a shunt resistor directly at the strain gage bridge.

---

## **CHOOSING THE RIGHT TORQUE TRANSDUCER**

---

When choosing a torque transducer, one of the primary considerations is selecting the right capacity. On one hand, if you choose too large a range, the accuracy and resolution may not be enough for the application. On the other hand, if you choose too small a size, the sensor may be damaged due to overload, which is an expensive mistake.

We'd much rather have happy customers with functioning systems. In the end, the customer takes final responsibility for choosing the proper size for his application.

To select the proper size, first determine the amount of torque you want to

measure. This can be easy or hard, depending on your application. An easy example would be a fastener torque application, where a certain amount of torque is to be applied to a fastener. A more difficult application might be trying to figure out how much torque is required for a new design wind turbine

If there's a motor involved, you can usually read the rated HP and RPM off the nameplate. Once you know that, average running torque can be calculated from one of the following equations:

$$\text{Torque in lb-ft} = (\text{Horsepower} \times 5,252) / \text{RPM}$$

$$\text{Torque in lb-in} = (\text{Horsepower} \times 63,024) / \text{RPM}$$

$$\text{Torque in Nm} = (\text{Horsepower} \times 7,121) / \text{RPM}$$

After you determine the maximum average running torque of the system, the next step is to decide how much safety-factor you need to prevent overloading the sensor. In rotary torque, there is always one side of the sensor being driven, and the other side being loaded. Some drives and loads stress the torque transducer more than others. These drive and load factors must be considered when determining the maximum peak torque in the system.

Load service factors from one to four can be assigned to different types of loads, with one being the least severe. Examples of service factor one devices are smooth running, constant rpm items such as fans and centrifugal blowers. Liquid pumps and axial compressors also fall into this category.

Going up the scale, load service factor two devices are non-reversing, non-constant load or start/stop devices. Examples include briquetting machines, cranes and hoists, conveyors, extruders and mixers.

Load service factor three devices involve high variable shock or light reversing loads. Examples include crushers, single cylinder reciprocating pumps, vehicle drivelines and hammer mills.

Load service factor four devices are the most severe and involve heavy to full torque reversals including reciprocating compressors.

Next you must consider drive service factors. Much the same as loads, different types of drives offer different levels of severity, influencing the maximum expected peak torque in an application.

Drive service factor zero devices are the easiest and include turbines or smooth running DC or 3-phase AC motors. Factor 0.5 devices include 8-cylinder gas or 10-cylinder diesel engines and single-phase AC motors. Moving up the scale, drive service factor one devices include 6-cylinder gas or 8-cylinder diesel engines, and 3-phase AC motors controlled by variable frequency drives.

Examples of drive service factor 1.5 devices include 4-cylinder gas or 6-cylinder diesel and single-phase VFD controlled AC motors. Topping out the range with drive service factors from 2 to 4 include less than 4-cylinder gas and less than 6-cylinder diesel engines. Diesel engines have high compression ratios and cause torque peaks that can be 4x or 6x the average running torque, leading to rapid use of the fatigue life and premature transducer failure.

Finally, consider startup conditions. When starting a high inertia load with an electric motor, very high peak torque can result. One thing to check is the starting torque rating of the motor if you can find it. Diesel engines can also have very high starting and stopping torques of 6x running torque.

Maximum expected peak torque can be calculated by taking the above factors into consideration. Peak torque is equal to average running torque x (load service factor + drive service factor). This is the recommended capacity of your torque transducer.

For example, consider a briquetting machine being driven by a VFD controlled 3-phase AC motor. The motor is rated for 150 hp at 1790 rpm. From the equation above, calculated average running torque in Nm is  $(7121 * 150) / 1790 = 597$  Nm. A briquetting machine has load service factor two and the VFD controlled 3-phase AC motor has a drive service factor one. Adding these together we get combined service factor three. We then multiply  $3 * 597$  Nm to get 1790 Nm as the expected peak torque. In this case a torque transducer of at least 1790 Nm capacity would be selected.

Once the required capacity has been determined, it's important to consider the accuracy and resolution of the measurement. Torque transducer accuracies are usually quoted as a percentage of capacity. A common rating is 0.1% combined error. For example, 1000Nm sensor, when used anywhere within its 1000Nm rating, will have nonlinearity and hysteresis error of no more than +/-0.1% of 1000Nm, or +/-1Nm.



When measuring an average running torque of 800Nm with this sensor, the +/-1Nm may be just fine. However, if the application has a very low ratio of average running torque to maximum peak torque, it may be necessary to use this same transducer to measure a running torque of 100Nm. In this case, +/-1Nm out of 100Nm is a 1% error.

**TIP: Choosing a transducer with enough capacity to survive the application can make it difficult to achieve high accuracy. As always, compromises must be made.**

Another way to allow for high overloads while still accurately measuring smaller torque values is to use a multi-range sensor.

For example, if you have a system with high load and service factors you might have a relatively low running torque but high peak values. If you want to accurately measure both the running and the peak torques then a dual-range sensor would be a good choice. Ratios of high to low capacity on dual range torque transducers are typically 5:1 or 10:1. The safe overload rating of the sensor is equal to 2x the higher range

Some newer sensors, such as the Interface model AxialTQ.

Another factor to consider is resolution of the measurement signal. Analog sensors such as slip- ring or rotary transformer types have essentially infinite resolution, limited by the signal to noise ratio of the system.

Digital rotary torque transducers are subject to the bit resolution of their analog to digital converters. Typical digital sensors are 12 or 16-bit or higher. A 12-bit sensor has 4096 counts over its -Full Scale to +Full Scale range. What this means is the resolution over one direction of the measuring range (CW or CCW), is 2048 counts. For a 1000Nm 12-bit sensor, resolution is therefore about 0.5Nm. If that's not sufficient, a higher resolution sensor should be selected. In contrast, a 16-bit 1000Nm sensor will have 0.03Nm and an 18-bit 1000Nm sensor has 0.008Nm resolution.

---

## SHAFT OR FLANGE STYLE?

---

Torque transducers typically come in one of two major mechanical configurations, shaft or flange style. Shafts can be either smooth or keyed with keyed shafts coming in either single or double-keyed versions. Flange style sensors are typically shorter than shaft style, and have pilots on their

flange faces as a centering feature.

Smooth shafts offer some advantages over their keyed counterparts, including more uniform introduction of the torque into the measuring shaft, ease of assembly and disassembly and zero backlash. A coupling designed for use with smooth shafts will have some method of clamping to the shaft. This is commonly accomplished with split collars or shrink-disk style hubs. Shrink-disk style hubs usually include features to aid in their removal from the shaft.

Hubs for keyed shafts are simpler than those for smooth shafts and cost less but can suffer from wear due to backlash, especially in reciprocating applications. To prevent backlash, the hub must be installed on the keyed shaft with an interference fit, which is usually accomplished by either heating the hub before installation or pressing the hub onto the shaft.

Pressing of the hub risks damaging the sensor and both installation methods present problems with removal. Another less common method of installation and removal uses special hydraulic equipment. In the higher torque capacities double keyways are often used, spaced at 180 degrees around the shaft.

The two main categories of coupling are single and double flex, also referred to as half and full couplings. A single-flex coupling has flex point and allows only angular misalignment. Radial misalignment, perpendicular to the axis of rotation, is not possible. A double flex has two flex points and allows both angular and radial misalignment.

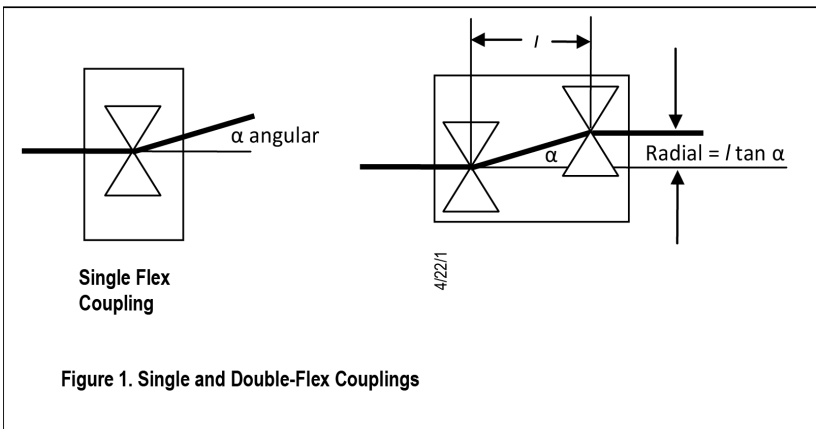

Some available styles of coupling are flexible disk couplings which are desirable for torque measurement because of their high torsional rigidity and zero backlash. Torsional rigidity allows for fast dynamic response and low wind-up. A less rigid coupling will mechanically dampen the signal, possibly reducing or eliminating the ability to measure transient events. Another desirable quality of flexible disk couplings is they can be balanced for high RPM operation.

Rotary torque transducers come either supported on bearing in a housing or are bearingless. Bearing supported designs maintain alignment between the rotating and stationary parts of the sensor and can be easier to mount. Bearingless sensors require the non-rotating part of the sensor to be held in a precisely fixed position relative to the rotating part. Some bearingless sensors are more forgiving of alignment issues than others.

## INSTALLATION METHODS

There are two main methods of mounting rotary torque transducers, fixed or floating. Fixed mount applies only to sensors with bearings and involves attaching the sensor housing to a fixed support.

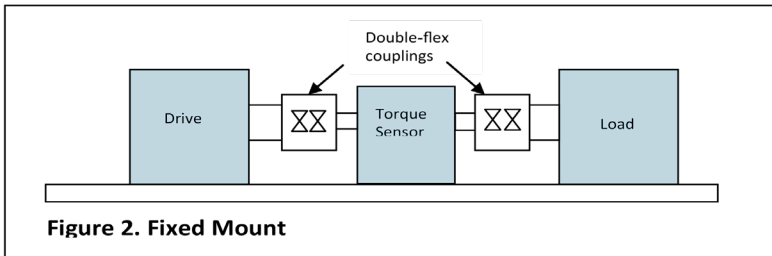

In floating installations, the sensor is supported only by its drive and load side connections, which are typically single-flex style couplings. A flexible strap keeps the torque transducer housing from rotating. Bearingless sensors are always floating mount.

Fixed mounting requires that the sensor housing have a means to attach it to the support. Sometimes the mount is an option on the sensor and sometimes the foot or pedestal mount is built as part of the sensor. The simplest fixed-mount design sensors include a flat machined surface on the

housing with threaded mounting holes. In fixed mount installations, double flex couplings must be used.

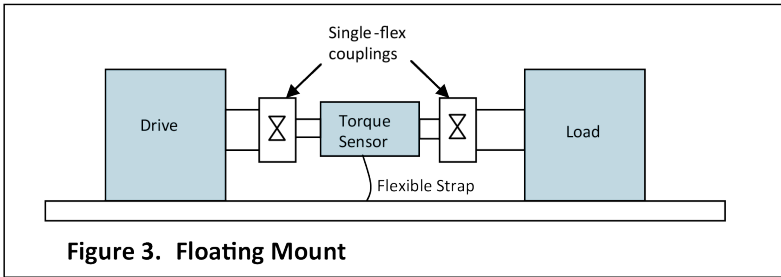

Fixed mount can be better for high rpm use, limiting the lengths of the unsupported rotating sections. Foot or pedestal mounted sensors are not designed to be used as bearing blocks, so care must be taken to ensure against unduly loading the bearings. An example of a fixed mount application is electric motor testing, where it's important to quickly move motors in and out of the test stand. By mounting the torque transducer and load to a fixed plate, the alignment between the two can be set once and maintained indefinitely. The test motor can then be coupled and uncoupled from the sensor with no worries about the sensor losing its support each time the motor is disconnected. In contrast, if the sensor is float mounted, each time the motor is disconnected the torque transducer must be supported from drooping.

Floating mounts are more forgiving of misalignment between the drive and load. A floating sensor, mounted between two single-flex couplings, is essentially a long double-flex coupling. Since the allowable radial misalignment is directly proportional to the distance between flex points, the floating mount installation is more tolerant of misalignment between the drive and load.

Another advantage of floating mounts is the reduction of the effect of extraneous loads on the sensor. For example, in a floating mount system, a thrust load is carried only by the sensing element with no effect on the bearings. In a fixed mount installation, any thrust load becomes a load on the bearings, causing premature wear in the bearing and possibly contact between the rotating and stationary parts if the shaft shifts within the housing. The thrust load rating of a floating mount sensor is typically

orders of magnitude greater than a fixed mount.

As with any sensor, environmental factors must be considered. Some things to consider are temperature and exposure to moisture or dust. For temperature, rotating torque transducers usually have a storage range, an operating range and a rated or compensated range.

The storage range is the temperature over which the sensor can be stored without damage. While it won't hurt the sensor to store it within this range, it must be used within its operating range, or it might be damaged. The compensated or rated range is the temperature over which the torque transducer is guaranteed to meet its published temperature specifications. Depending on the sensor, the temperature performance will be two or more times worse when outside the rated range. If the sensor must be exposed to temperature extremes, then steps should be taken to shield or protect it. Heating blankets or enclosures are sometimes used.

Another environmental factor to consider is electrical noise. Some installations are noisier than others, especially where electric motors and/or variable-frequency drives are employed. Variable-frequency drives (VFD) are used to control the speed of an AC electric motor by controlling the frequency of the electrical power supplied to the motor. Other names for VFD are adjustable-speed drives (AFD), AC drives, inverter drives or variable-speed drives (VSD).

When a torque transducer is used in conjunction with a VFD, proper grounding and shielding techniques must be used to prevent torque transducer malfunction. During operation, a VFD creates noise on the power line and radiates noise from the VFD-to-motor cable. Noise is also capacitively coupled from the motor windings into the motor shaft and through the bearings into the motor frame, and from unshielded motor leads in a conduit to the conduit supports.

To ensure a successful installation, the VFD supplier grounding recommendations should be followed, including use of a shielded motor feed cable.

In rotating torque measurement, the sensor will be spinning, so it's important to know what the maximum RPM will be and to make sure the torque transducer can withstand it. Limiting factors may be bearing life, rotating electronics or balancing, depending on the type of sensor. You

must also consider the limits of other parts in the rotating assembly such as couplings. Typically, rotating parts will have a published rpm limit. Sometimes those limits can be increased with special balancing or special component parts. If in doubt, please check with the sensor provider.

Rotating torque measurement is rarely a steady value, more commonly varying around some average value. In certain only the average torque is important, but in other cases the transient torque peaks are of interest. In either case it's important to understand the sampling rate and/or measurement bandwidth of the system.

Rotating torque transducers should always list a measurement bandwidth and/or a sampling rate on their data sheets. Depending on the type, bandwidth can range from a couple of hundred Hz to several thousand or more. An application where average running torque is typically measured is engine dynamometers. In this case you may not care about torque spikes caused by individually firing cylinders so they can be filtered out, either by the sensor or in the data acquisition electronics.

In other cases, the peaks and valleys of the torque signal are important, and a sensor with enough bandwidth must be selected. For example, in an end of assembly line gearbox test it may be important to check if one of the individual gear teeth is broken or if the gears aren't seated properly. This could be determined by comparing the torque signature of the tested part to a known good one. In a 1:1 ratio right-angle gearbox with 60-tooth gears spinning at 500 rpm, a tooth engages 500 times per second. To accurately profile the tooth engagement, you would need a torque transducer with bandwidth of at least 500 Hz.

The proper selection of a torque transducer can be confusing when considering the variables, specifications and use cases. Careful attention must be given to proper capacity, speed, connection, mounting and environment. Interface Application Engineers are an excellent resource to assist you in defining your requirements. You can also find a useful tool online, the Interface Torque Selection Guide, to get you started in your review.

# **interface**

**FORCE MEASUREMENT SOLUTIONS.**

Interface® is the trusted The World Leader in Force Measurement Solutions®. We lead by designing, manufacturing, and guaranteeing the highest performance load cells, torque transducers, multi-axis sensors, and related instrumentation available. Our world-class engineers provide solutions to the aerospace, automotive, energy, medical, and test and measurement industries from grams to millions of pounds, in hundreds of configurations. We are the preeminent supplier to Fortune 100 companies worldwide, including; Boeing, Airbus, NASA, Ford, GM, Johnson & Johnson, NIST, and thousands of measurement labs. Our in-house calibration labs support a variety test standards: ASTM E74, ISO-376, MIL-STD, EN10002-3, ISO-17025, and others.



You can find more technical information about load cells and Interface®'s product offering at [www.interfaceforce.com](http://www.interfaceforce.com), or by calling one of our expert Applications Engineers at 480.948.5555.







