

4850 Battery Powered Bluetooth Weight Indicator



Operating Manual

Released June 23, 2023

Contents

DISPLAY & KEYPAD DETAILS	2
INSTALLATION & OVERVIEW	5
INSTALLATION	5
GETTING STARTED.....	6
INSTRUMENT CONFIGURATION	7
CONFIGURATION MENUS	7
ENTERING THE SETUP (“F”) CONFIGURATION MENU	7
SETUP (“F”) MENU DESCRIPTIONS	8
ENTERING THE USER (“A”) OR COM (“C”) MENU	10
USER (“A”) AND COM (“C”) MENU DESCRIPTIONS	11
INSTRUMENT CALIBRATION.....	12
CALIBRATION OVERVIEW	12
LIVE CALIBRATION OVERVIEW	12
LIVE SPAN CALIBRATION INSTRUCTIONS (F17)	13
LIVE NEGATIVE SPAN CALIBRATION INSTRUCTIONS (F15).....	13
LIVE ZERO CALIBRATION INSTRUCTIONS (F16).....	14
KEY-IN MV/V CALIBRATION INSTRUCTIONS (F27)	14
ADVANCED OPERATION	16
PEAK HOLD MODE	16
SERIAL PORT INFORMATION	17
SERIAL PORT MODES.....	17
OUTPUT STRINGS.....	18
SPECIFICATIONS	19
ERROR MESSAGES.....	19
TROUBLESHOOTING	20

DISPLAY & KEYPAD DETAILS

This instrument uses a 6-digit LCD (Liquid Crystal Display) with adjustable LED backlight. The Table below summarizes the display annunciators.



Symbol	Display Indication
→0←	Displays when the instrument reading is at Zero.
P	The instrument is in Peak Hold mode.
lb	The displayed force reading is in pounds (lbf).
kg	The displayed force reading is in kilograms (kgf).
g	The displayed force reading is in grams (gf).
oz	The displayed force reading is in ounces (ozf).
	The displayed force reading is in Newtons (N).
N	The displayed reading is negative (minus).
▲▼	Displays whenever the instrument reading is at rest, i.e., not in motion.
🔋	When blinking, the battery <u>needs to be replaced</u> soon.

Notes about the backlight:

1. If no keys are pressed within 60 seconds, the backlight will switch off to save battery life.
2. You can wake up the backlight by pressing any key.

The keypad comprises five (5) function keys.



Marking	Keypad Function
Units	Selects the displayed unit of measure, e.g., lbf, kgf and N.
Peak	Selects the peak hold display mode of the instrument, e.g., live data, positive peak and negative peak. (This function must first be enabled using the F36 parameter)
Zero	Zeroes the force display reading.
Data	Sends the displayed data to the serial communication port.
On/Off	Press and hold for a few seconds to turn the instrument ON. Press and hold for about five seconds to shut the instrument OFF.

Note: This unit automatically zeroes when powered ON, regardless of the applied load, its polarity, or its stability.

INSTALLATION & OVERVIEW

Remember that the installer is ultimately responsible to assure that a particular installation will be and remain safe and operable under the specific conditions encountered.

The instrument must be properly configured and calibrated prior to use.

Installation

Find a suitable location for the instrument and use the included bracket to mount the unit to a wall or table. Use this handy guide for mounting the bracket to a wall or table:

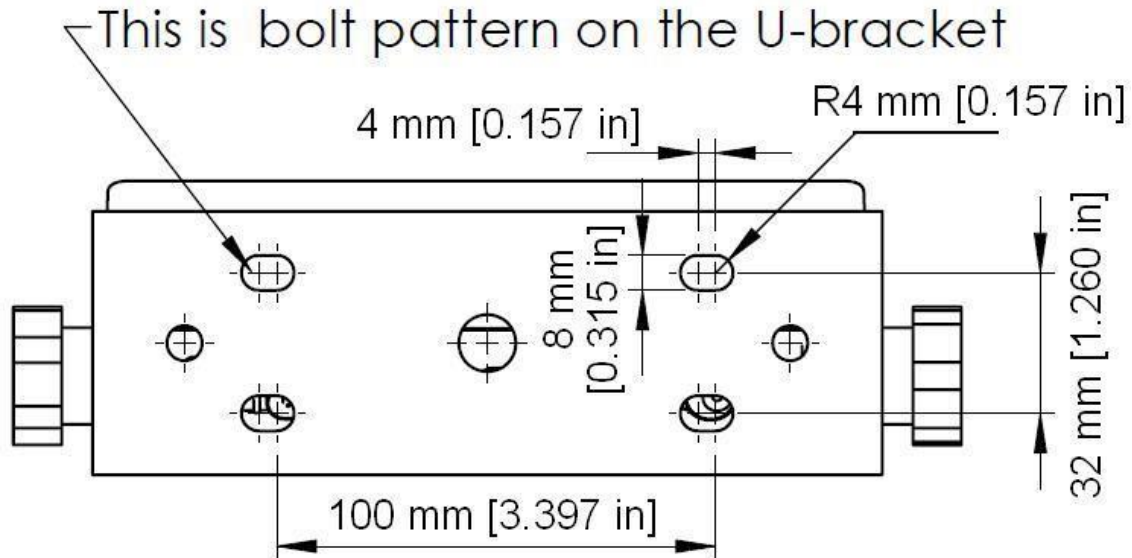

The INSTRUMENT ships with a force sensor cable which plugs into the appropriate connector. Use the following color codes to connect the force sensor.

Force Sensor Cable Leads

Color	Function	Color	Function
Black	- Excitation	White	- Signal
Red	+ Excitation	Green	+ Signal

The INSTRUMENT features one full duplex RS-232 serial port, designed for connection to a computer or a serial printer. The same port may be also used as a simplex, RS-232 port designed for connection to a remote display.

DSUB9 Connector

Pin No.	Wire Name
2	RXD
3	TXD
5	Ground

The INSTRUMENT requires 4-AA batteries to operate. To install the batteries, remove the plastic battery cover from the rear panel. Observe proper direction (polarity) of the batteries. Replace the battery cover.

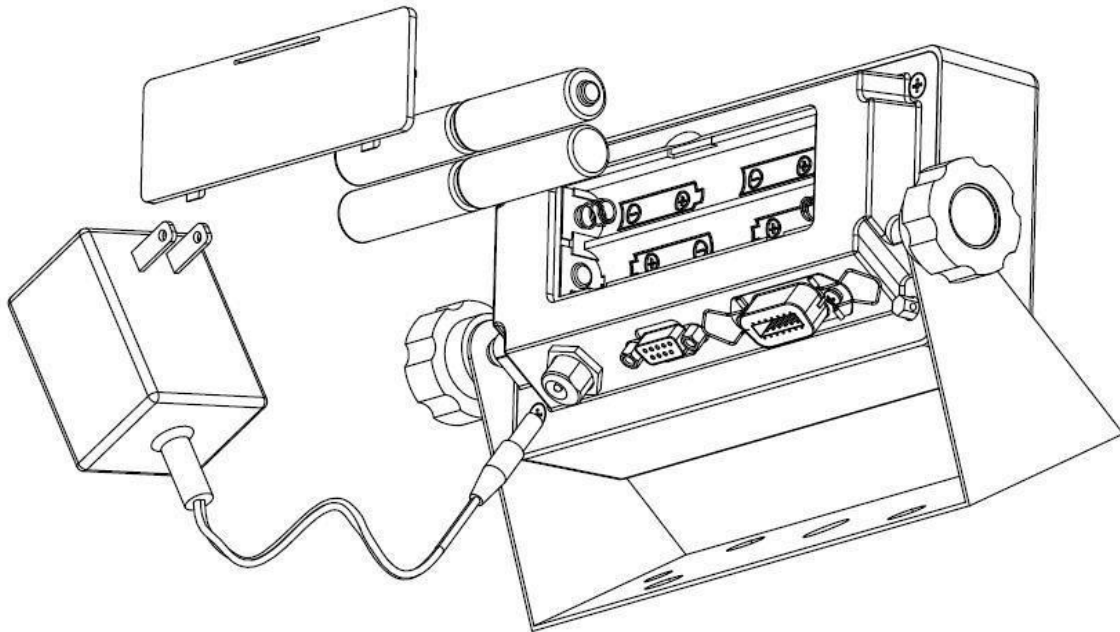

The INSTRUMENT may also be powered by the included AC wall adaptor.

Getting Started

1. Press and hold the ON/OFF key on the instrument for two seconds.
After a brief initialization period, the instrument will revert to a zero ("0") force reading.

Your instrument is now ready for configuration and calibration.

INSTRUMENT CONFIGURATION

Configuration Menus

The Model 4850 contains three (3) menus to configure the instrument:

Setup (“F”) Menu – Configures all metrologically-related parameters including calibration procedures.

User (“A”) Menu – Configures COM2 communication parameters and other misc. parameters, e.g., automatic turn off.

COM1 (“C”) Menu – Configures COM1 communication parameters.

The configuration menus are laid out in the following vertical arrangement:

- Top [Menu selection] level
- Parameter level
- Selection level (or function level, e.g., span calibration)

Please review the following chart to get a feel for how to navigate among the various menus and parameters.

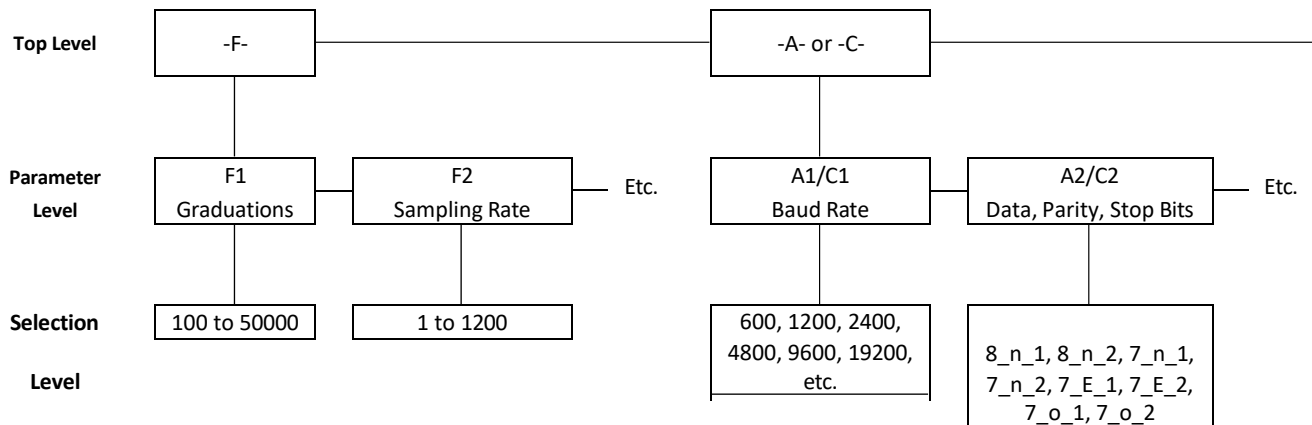

Entering the Setup (“F”) Configuration Menu

1. Switch off the instrument by pressing and holding down the ON/OFF key for about 5 seconds.
2. Press and hold down the ON/OFF key (about 20 seconds) until the screen shows “-F-”.
3. Scroll down using the PEAK (down) key to reach the parameter level. The instrument shows “F 1”.
4. Move from one “F” menu parameter to the next by using the DATA (left) or ON/OFF (right) keys. For example, to go from F1 to F2, press the ON/OFF key. To go from F2 back to F1, press the DATA key.

5. Once you have arrived at the proper "F" menu parameter, e.g., "F 1", press the PEAK (down) key once to arrive at the selection level. The instrument displays the current parameter setting.
6. If there is a selection list, scroll thru the available parameter settings, use the DATA (left) or ON/OFF (right) keys. Otherwise, use the arrow keys to adjust the displayed value to the new value.
7. Once the setting you want is displayed on the screen, press the ZERO (set) key to save this value and revert up to the parameter level, e.g., "F 1".

To save all parameter settings, it is imperative to exit all menus in the following manner: At the parameter level, press the UNITS (up) key twice (two times) to exit the Setup Menu. The instrument displays 'SAvE' and then automatically powers off.

Setup ("F") Menu Descriptions

This section provides more detailed descriptions of the selections found in the Setup Menu Chart. Factory-set defaults are shown in **bold** with a checkmark; (✓).

CODE/NAME	DESCRIPTION	SELECTION LIST
F1 Graduations	Sets the number of full-scale graduations, i.e., capacity ÷ division. DO NOT CHANGE	Key-in 100 - 50000 50000 ✓
F2 Sampling Rate	Sets the sampling rate in Hertz (measurements per second).	Key-in 1 – 1200 100 ✓
F6 Digital Filter	Sets the number of measurements to be averaged to affect the speed and stability of the readings. A lower number provides a faster response. Choose the value that works best for your application.	0 to 12 8 ✓
F8 Calibration Unit	Sets the force unit of measure to be used in the calibration process. "1" = unit is lbf "2" = unit is kgf "3" = unit is ozf "4" = unit is gf "6" = unit is kN (kilonewton) "7" = unit is kip (kilopound)	1 ✓ 2 3 4 6 7
F9 Display Divisions	Sets the interval value. Use together with F10.	1 ✓ 2 5
F10 Decimal Pt.	Sets the decimal point value. Use together with F9.	0 ✓ 0.0 0.00 0.000 0.0000 00

CODE/NAME	DESCRIPTION	SELECTION LIST
F15 Span Calibration - Negative	Places instrument into live negative (-) span calibration mode. Scrolling down with the PEAK key one level begins the procedure.	Press PEAK key to begin sequence
F16 Zero Calibration	Places instrument into live zero-calibration mode. Scrolling down with the PEAK key one level begins the procedure.	Press PEAK key to begin sequence
F17 Span Calibration - Positive	Places instrument into live positive (+) span calibration mode. Scrolling down with the PEAK key one level begins the procedure.	Press PEAK key to begin sequence
F18 View Calibration Data	Activates the function that allows you to view calibration values. Scrolling down with the PEAK key one level begins the procedure.	Press PEAK key to begin sequence
F19 Key-in Zero	Allows you to key-in a known zero calibration value. Scrolling down with the PEAK key one level begins the procedure.	Press PEAK key to begin sequence
F20 Key-in Span	Allows you to key-in known span calibration values. Scrolling down with the PEAK key one level begins the procedure.	Press PEAK key to begin sequence
F21 Factory Reset (US)	This sub-menu will reset all parameters in the "F" and "A" menu to the default settings. It will not overwrite any previously saved calibration data. USE WITH CAUTION!	Press the PEAK key twice to execute
F22 Factory Reset (EU)	This sub-menu will reset all parameters in the "F" and "A" menu to the default settings. It will not overwrite any previously saved calibration data. USE WITH CAUTION!	Press the PEAK key twice to execute
F23 Full Factory Reset	This sub-menu will reset all instrument parameters to the default settings. It will not overwrite any previously saved calibration data. USE WITH EXTREME CAUTION!	Press the PEAK key twice to execute
F25 Set Point Function	Sets the function of the set points and relay outputs.	0 to 10 0 ✓
F26 Calibration Mode	Sets the instrument calibration mode. "no" = Live, "yE5" = Key-In (mV/V)	no ✓ yE5
F27 Key-in Calibration	Places instrument into key-in (mV/V) calibration mode. Scrolling down with the PEAK key one level begins the procedure.	Press PEAK key to begin sequence
F28 Reference Calibration	Places instrument into reference (mV/V) calibration mode. Scrolling down with the PEAK key one level begins the procedure. Factory Use Only. Password protected.	Press PEAK key to begin sequence
F30 Application	Sets one special application. "0" = None (Gross/Net), "2" = Remote Display, "5" = Peak Hold, "	0 2 5 ✓

CODE/NAME	DESCRIPTION	SELECTION LIST
F31 Quick Cal	Sets the calibration stability level. Enable for hydraulic sensor calibration. "no" = Disabled "YES" = Enabled	No ✓ YES
F35 Default Units Mode	Sets the force unit of measure to be displayed when the instrument is switched on. "1" = Pounds (lbf), "2" = Kilograms (kgf), "3" = ounces (ozf), "4" = grams (gf), "5" = Newtons (N) "6" = Kilonewtons (kN) "7" = Kilopounds (kips)	1✓ 2 3 4 5 6 7
F36 Default Peak Hold Mode	Sets the peak hold mode to be activated when the instrument is first switched on. "rEAL" = Live, "hoLd P" = Positive Peak, "hoLd U" = Negative Peak	rEAL✓ hoLd P hoLd U

Entering the User ("A") or COM ("C") Menu

NOTE: Follow the same steps to enter the COM ("C") Menu– just substitute "C" for "A" below

1. Switch off the instrument by pressing and holding down the ON/OFF key for about 5 seconds.
2. Press and hold down the ON/OFF key (about 20 seconds) until the screen shows "-F-".
3. Press the ON/OFF (right) key once. The screen displays "-A-".
4. Scroll down using the PEAK (down) key to reach the parameter level. The instrument shows "A 1".
5. Move from one "A" parameter to the next by using the DATA (left) or ON/OFF (right) keys. For example, to go from A1 to A2, press the ON/OFF key. To go from A2 back to A1, press the DATA key.
6. Once you have arrived at the proper "A" menu parameter, e.g. "A 1", press the PEAK (down) key once to arrive at the selection level. The instrument displays the current parameter setting.
7. If there is a selection list, scroll thru the available parameter settings, use the DATA (left) or ON/OFF (right) keys. Otherwise, use the arrow keys to adjust the displayed value to the new value.
8. Once the setting you want is displayed on the screen, press the ZERO (set) key to save this value and revert up to the parameter level, e.g. "A 1".
9. To save all parameter settings, it is imperative to exit all menus in the following manner: At the parameter level, press the UNITS (up) key twice (two times) to exit the User Menu. The instrument displays 'SAVE' and then automatically powers off.

User (“A”) and COM (“C”) Menu Descriptions

This section provides more detailed descriptions of the selections found in the User Menu Chart. Factory-set defaults are shown in **bold** with a checkmark; (√).

CODE/NAME	DESCRIPTION	SELECTION LIST
A1/C1 Baud Rate	Selects the baud rate for data transmission through the serial port.	600, 1200, 2400, 4800, 9600 √, 19200, 38400, 57600, 115200
A2/C2 Data Bits, Parity and Stop Bits	Selects the number of data bits and parity of serial transmission. "8_n_1" = 8 data bits with no parity bit and one stop bit "8_n_2" = 8 data bits with no parity bit and two stop bits "7_n_1" = 7 data bits with no parity bit and one stop bit "7_n_2" = 7 data bits with no parity bit and two stop bits "7_E_1" = 7 data bits with even parity bit and one stop bit "7_E_2" = 7 data bits with even parity bit and two stop bits "7_o_1" = 7 data bits with odd parity bit and one stop bit "7_o_2" = 7 data bits with odd parity bit and two stop bits	8_n_1 √ 8_n_2 7_n_1 7_n_2 7_E_1 7_E_2 7_o_1 7_o_2
A3/C3 Serial Port Mode	Selects the mode of the serial port: Refer to Serial Port Information for more details. "0" = Demand Full Duplex "1" = Continuous Full Duplex "2" = Auto Print	0 √ 1 2
A6/C6 Output String	Selects fixed output string for serial port. Refer to Serial Port Information for more details. "0" = String Format 1 (Condec Demand) "1" = String Format 2 (Condec Continuous) "2" = Text Print Ticket "3" = Text Print Ticket with MP-20 Auto Label Feed	0 √ (A6) 1 2 √ (C6) 3
A8 ID Number	Selects ID Number for serial port. Factory Use Only. Password protected.	Press PEAK key to begin sequence
A10 Auto Power Off	Selects the automatic power off time, expressed in minutes of inactivity (keys and force measurement change). Pressing the PEAK key to scroll down one level begins the sequence.	Key-in 0 to 30 30 √
A12 Backlight Brightness	Selects the brightness of the LCD backlight. Selections are in % of full brightness. Intended to help save battery life.	0 (OFF) 20 50 75 100 √
A22 Low Battery Auto Power Off	Selects the automatic power off time of the instrument after it enters a low battery condition. Expressed in minutes. Pressing the PEAK key to scroll down one level begins the sequence.	Key-in 0 to 99 02 √
A23 Audible Key Feedback	Selects function of the audible key feedback (beeper). "no" = Disabled "YES" = Enabled	no YES √

INSTRUMENT CALIBRATION

Calibration Overview

There are two ways to calibrate the instrument:

1. **Live calibration:** You will be calibrating an actual load sensor to the instrument using live test loads. You can have up to seven positive calibration points and up to seven negative calibration points. These calibration points are denoted as C1 through C7.
2. **mV/V calibration:** You will be calibrating the instrument using a load cell simulator (calibrator). Previously established mV/V input signal values - and the corresponding force values - are required. You can have up to six positive calibration points and up to six negative calibration points. These calibration points are denoted as C1 through C6.

The absolute value of each subsequent calibration point should be higher than the last, e.g., the C2 value should be greater than the C1 value, etc.

Live Calibration Overview

Live calibration comprises two main steps: **zero** (F16) and **span** (F17). A third calibration menu for **negative span** (F15) is also available for systems operating in both tension and compression.

What follows is the recommended live calibration sequence. **Any deviations from this may cause unwanted behavior:**

1. Place the force sensor onto your test fixture, with no other forces applied.
2. Navigate to F17 (span calibration) and press the PEAK (down) key; indicator prompts for the first calibration point, C1.
3. Key in number 111111 and press the ZERO (set) key; indicator will show "FIT" momentarily and then resume its prompt for the first calibration point, C1.
4. Follow the F17 procedure (see next section) for up to seven span calibration points.
5. Optional: repeat steps 2-4 for negative span calibration (F15)
6. Mount the force sensor onto its final fixture.
7. Navigate to F16 and perform the zero calibration.

Notes:

1. You may see dashes appear temporarily on the screen during live calibration. This simply means that the instrument is processing data.
2. To disable the positive calibration slope, simply enter a zero value (e.g., "0.0") for C1 while in F17.
3. To disable the negative calibration slope, simply enter a zero value (e.g., "0.0") for C1 while in F15.

Live Span Calibration Instructions (F17)

1. While in the Setup mode, scroll to "F 17", and then scroll down once using the PEAK (down) key. The indicator will briefly display 'C 1' and then prompt you to enter the data for the first calibration point (C1). The previously saved force value will be displayed with one digit blinking.
2. Use the four directional keys to adjust the displayed value to 111111 and press the ZERO (set) key; indicator will show "FIT" momentarily and then automatically record the fixture reference point. The previously saved force value will be displayed with one digit blinking.
3. Apply the first test load to the force sensor.
4. Use the four directional keys to enter in the actual positive force value, e.g., 1000.0 lbf. Increase the flashing digit by pressing the UNITS key. Decrease the flashing digit by pressing the PEAK key. Pressing the DATA key or the ON/OFF key will change the position of the flashing digit.
5. Press the ZERO (set) key to save the value. The indicator briefly displays 'End C1' and then moves to the next calibration point (C2).
6. Repeat steps 3 through 5 to enter data for the remainder of the calibration points. **You need not enter data for all seven calibration points. To cease entering additional calibration points, simply enter zero for the new value, e.g., 0.0 lbf.**
7. At the conclusion of C7 (or the last calibration point), the instrument will show "-donE" and reverts to the top setup menu level, i.e.: "-F-".

If the calibration was *not* successful, one of the following error messages will appear.

- "Err0" - The calibration test load or the keyed-in load is larger than the full capacity of the instrument. Change the calibration test load or check the input data.
- "Err1" - The calibration test load or the keyed-in load is smaller than 1% of the full capacity of the instrument. Change the calibration test load or check the input data.
- "Err2" – There is not enough signal from the force sensor to complete the calibration process. Most common causes include incorrect force sensor wiring, a mechanical obstruction or a faulty (damaged) force sensor.

Take the indicated action to correct the problem, and then perform a new calibration.

To save all calibration settings, you must exit all menus in the following manner: At the parameter level, press the UNITS (up) key twice (two times) to exit the Setup Menu. The instrument displays 'SAvE' and then automatically powers off.

Live Negative Span Calibration Instructions (F15)

For negative calibration data, you will not see a minus sign on the screen. You need not be concerned as all data entered is presumed to be a negative value, e.g., 1000.0 lbf is really -1000.0 lbf.

1. While in the Setup mode, scroll to "F 15", and then scroll down once using the PEAK (down) key. The indicator will briefly display 'C 1' and then prompt you to enter the data for the first calibration point (C1). The previously saved force value will be displayed with one digit blinking.

2. Use the four directional keys to adjust the displayed value to 11111 and press the ZERO (set) key; indicator will show "FIT" momentarily and then automatically record the fixture reference point. The previously saved force value will be displayed with one digit blinking.
3. Apply the first test load to the force sensor.
4. Use the four directional keys to the actual positive force value, e.g., 1000.0 lbf. Increase the flashing digit by pressing the UNITS key. Decrease the flashing digit by pressing the PEAK key. Pressing the DATA key or the ON/OFF key will change the position of the flashing digit.
5. Press the ZERO (set) key to save the value. The indicator briefly displays 'End C1' and then moves to the next **negative** calibration point (C2).
6. Repeat steps 3 through 5 to enter data for the remainder of the calibration points. **You need not enter data for all seven calibration points. To cease entering additional calibration points, simply enter zero for the new value, e.g., 0.0 lbf.**
7. At the conclusion of C7 (or the last calibration point), the instrument will show "-donE" and reverts to the top setup menu level, i.e.: "-F-".

To save all calibration settings, you must exit all menus in the following manner: At the parameter level, press the UNITS (up) key twice (two times) to exit the Setup Menu. The instrument displays 'SAvE' and then automatically powers off.

Live Zero Calibration Instructions (F16)

1. While in the Setup mode, scroll to "F 16", and then scroll down once using the PEAK (down) key. The display will momentarily show "C 0" followed by a value. This value is the internal A/D count and can prove useful when trying to troubleshoot setup problems. If you see an 'N' on the screen, this indicates that the displayed value is negative (minus).
2. Mount the force sensor onto its final fixture, assure a no-load condition and then press the PEAK key to zero the display reading. Do NOT skip this step!
3. Quickly press the ZERO (set) key to save the zero-point value. The display will show "SET" and "EndC0" momentarily, and then revert up to F16.

To save all calibration settings, you must exit all menus in the following manner: At the parameter level, press the UNITS (up) key twice (two times) to exit the Setup Menu. The instrument displays 'SAvE' and then automatically powers off.

Underneath the display you may find down arrows which have been activated. For each down arrow displayed, add 1 million to the displayed count. (Max value is 4.8 million counts)

Key-in mV/V Calibration Instructions (F27)

You will be entering data for up to six **positive** calibration points and up to six **negative** calibration points. These calibration points are denoted as C1 through C6. The absolute value of each subsequent calibration point should be higher than the last.

Each calibration point requires entry of two values:

- A force value, e.g., 200 lbf
- A corresponding mV/V input signal value, e.g., 1.0125 mV/V.

1. While in the Setup mode, scroll to "F 27", and then scroll down once using the PEAK (down) key. The indicator will briefly display 'Pos C' and then prompt you to enter the data for the first **positive** calibration point (C1). The previously saved force value will be displayed with one digit blinking.
2. Use the four directional keys to enter in the actual positive force value, e.g., 200 lbf.
3. Press the ZERO (Set) key to save the force value. The indicator will prompt you to enter the corresponding mV/V input signal. The previously saved mV/V value will be displayed with one digit blinking.
4. Use the four directional keys to enter in the actual mV/V value.
5. Press the ZERO (Set) key to save the mV/V value. The indicator briefly displays 'End C1' and then moves to the next **positive** calibration point (C2).
6. Repeat steps 2 through 5 to enter data for the remainder of the **positive** calibration points. **You need not enter data for all six positive calibration points. To cease entering additional calibration points, simply enter zero for both values, e.g., 0 lbf and 0.0000 mV/V.**
7. The indicator will briefly display 'Neg C' and then prompt you to enter the data for the first negative calibration point (C1). The previously saved force value will be displayed with one digit blinking.
8. Use the four directional keys to enter in the actual negative force value, e.g., 200 lbf. **For negative calibration data, you will not see a minus sign on the screen. You need not be concerned as all data entered is presumed to be a negative value, e.g., 200 lbf is really -200 lbf.**
9. Press the ZERO (Set) key to save the force value. The indicator will prompt you to enter the corresponding mV/V input signal. The previously saved mV/V value will be displayed with one digit blinking.
10. Use the four directional keys to enter in the actual negative mV/V value. **For negative calibration data, you will not see a minus sign on the screen. You need not be concerned as all data entered is presumed to be a negative value, e.g., 1.0125 mV/V is really -1.0125 mV/V.**
11. Press the ZERO (Set) key to save the value. The indicator briefly displays 'End C1' and then moves to the next **negative** calibration point (C2).
12. Repeat steps 8 through 11 to enter data for the remainder of the **negative** calibration points. **You need not enter data for all six negative calibration points. To cease entering additional calibration points, simply enter zero for both values, e.g., 0 lbf and 0.0000 mV/V.**
13. When all values are entered successfully, the display will show "End Cx" momentarily before reverting to F27.

To save all calibration settings, you must exit all menus in the following manner: At the parameter level, press the UNITS (up) key twice (two times) to exit the Setup Menu. The instrument displays 'SAvE' and then automatically powers off.

ADVANCED OPERATION

Peak Hold Mode

This mode is used to capture peak forces measured during a specific process. These peak force values are held (frozen) on the screen. A common application is determining the breaking point of a part or assembly. The instrument captures both positive and negative peak forces. Peak forces are not retained when the instrument is powered OFF.

This mode of operation is enabled at the Factory [the F30 parameter = "5"]. Use the F36 parameter setting to select the default (power on) peak hold mode.

1. Push the PEAK key to activate the peak mode you want to use (repeat as needed):
 - "hoLd P" = Positive Peak; the "P" annunciator is ON.
 - "hoLd U" = Negative Peak; the "P" annunciator is ON
 - "LiVE" = Live Measurement (peak forces not captured); the "P" annunciator is OFF
2. Apply force to the item under test. The measured peak force is displayed on the screen.
3. To reset all peak values to zero, press and hold the PEAK key for about 3 seconds until the display shows "Clr P". This can be done in any peak hold mode.

SERIAL PORT INFORMATION

SERIAL PORT MODES

DEMAND DUPLEX MODE

The Demand Duplex Mode provides a two-way serial transmission mode. In this mode, the output information is transmitted on demand; either by pressing the DATA key on the instrument's front panel or upon receiving a recognized command from a host device (i.e., computer).

NOTE: Ensure that your cabling has a crossover (null modem) and contains the proper handshaking lines.

CONTINUOUS DUPLEX MODE

The Continuous Duplex Mode provides a two-way serial transmission mode. In this mode, the output information is transmitted continuously making it a popular choice for remote displays and other remote devices requiring a constant data stream. The transmission automatically occurs at the end of each display update. The instrument will react upon receiving a recognized command from a host device.

RECOGNIZED HOST COMMANDS (applies to both demand and continuous duplex modes)

ASCII code (Hex)	Symbol	Action by the instrument
50 or 70	P or p	Transmit the displayed force data through the serial port.
5A or 7A	Z or z	Zero the instrument
43 or 63	C or c	Change the displayed unit of measure
46 or 66	F or f	Transmit the firmware version through the serial port.

AUTO PRINT MODE

The Auto Print Mode provides a one-time serial transmission once a non-zero, stable condition is achieved.

OUTPUT STRINGS

TEXT PRINT TICKET

The Text Print Ticket is designed specifically for a serial printer.

GROSS 1000.0 lb

STRING FORMAT 1 (Condec Demand String)

String Format 1 is designed for two-way communication.

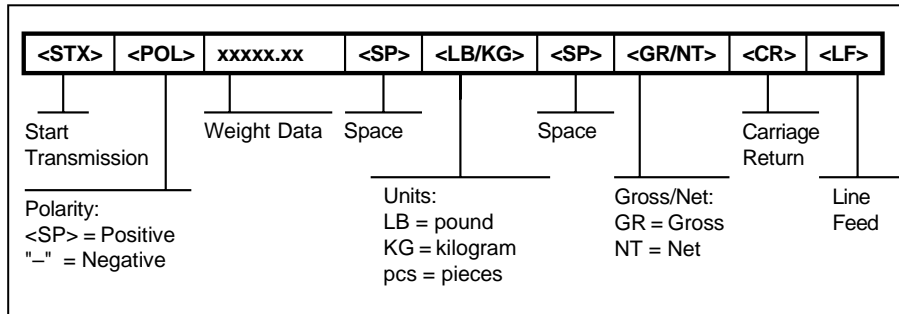

NOTE: Additional unit is available:

NT = Newtons
oz = ounce
g<space> = grams
lb = pounds
kg = kilograms

STRING FORMAT 2 (Condec Continuous String)

String Format 1 is designed for one-way communication.

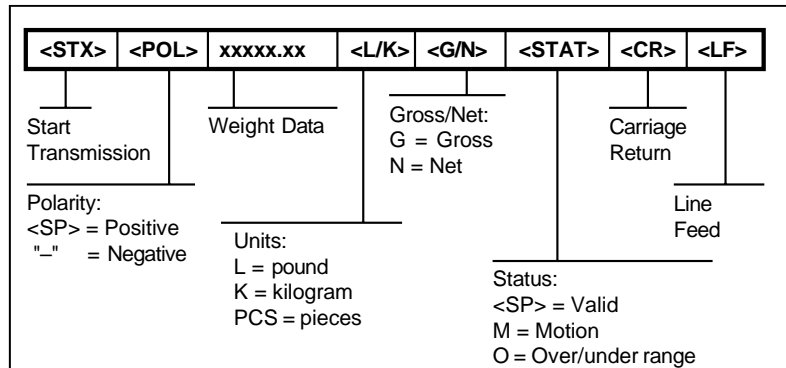

NOTE: Additional unit is available:

N = Newtons
O = oz
G = grams
L = pounds
K = grams

SPECIFICATIONS

Instrument Specifications

Enclosure: Aluminum/ABS enclosure (IP54)

Display: 0.8", 6-digit LCD with LED backlight

Upgraded A-to-D converter (AD-02):

Max. Signal Input: ± 4.5 mV/V

Resolution: Up to 4,800,000 Internal Counts @ 4.5 mV/V

Conversion Rate: 1 to 1200 Hz, selectable

Serial Port: Full Duplex RS-232C

Operating temperature: 14°F to 104°F (-10°C to 40°C)

Battery Power

- 4 AA alkaline
- User replaceable
- 85+ continuous hours of operation under typical operating conditions

ERROR MESSAGES

	Batteries need to be replaced.
Err 99	Setup menus blocked. Place internal calibration jumper back to its original position.
No-ad	A signal from the load sensor has not been detected.

TROUBLESHOOTING

Issue / Recommendation

“Low Battery” icon blinks on the digital readout, then the instrument powers off.

Replace the batteries.

Instrument turns off on its own.

The instrument has a power conservation feature, set to automatically power off the instrument after 30 minutes of non-use. If your needs require a different setting, call Interface Inc. Tech Support or installer.

Display is erratic or No-Ad message.

- A battery may be fully depleted. If so, this condition can cause erratic displays. Power off the instrument and replace the battery.
- Check the testing machine load cell for any obstructions or foreign debris
- Loose or faulty connection between the instrument and the load sensor
- Electromagnetic Interference (EMI). Call Interface Inc. Tech Support or installer

Warranty

All instrument products from Interface Inc., ('Interface') are warranted against defective material and workmanship for a period of (1) one year from the date of dispatch. If the 'Interface' product you purchase appears to have a defect in material or workmanship or fails during normal use within the period, please contact your Distributor, who will assist you in resolving the problem. If it is necessary to return the product to 'Interface' please include a note stating name, company, address, phone number and a detailed description of the problem. Also, please indicate if it is a warranty repair. The sender is responsible for shipping charges, freight insurance and proper packaging to prevent breakage in transit. 'Interface' warranty does not apply to defects resulting from action of the buyer such as mishandling, improper interfacing, operation outside of design limits, improper repair or unauthorized modification. No other warranties are expressed or implied. 'Interface' specifically disclaims any implied warranties of merchantability or fitness for a specific purpose. The remedies outlined above are the buyer's only remedies. 'Interface' will not be liable for direct, indirect, special, incidental or consequential damages whether based on the contract, tort or other legal theory. Any corrective maintenance required after the warranty period should be performed by 'Interface' approved personnel only.