



Operator Instructions for Load Pins

Operator Instructions for Load Pins

Table of Contents

Introduction.....	3
Markings CE.....	3
Electromagnetic Compatibility (EMC)	3
Load Pin Type/Model Number	3
Supplier	3
Service	3
Installation and Operation	3
Unpacking	3
Checks Prior to Installation	3
Installation	4
Wiring and Electrical Checks	5
Load Pin Output	5
Checks after Installation	6
Calibration	7
Warnings/Hazards	7
Inspection and Repair	8
Repair.....	8
Inspection.....	8
Load Pin Specification.....	8
Cable Gland and Connector Configurations	8
Mating Connector Assemblies	9
Load Pin Locking System Configurations	9
Installing a Locking and Anti-rotation System	10
Load Pin Output Options.....	11
Telemetry	11
Warranty.....	12

Operator Instructions for Load Pins

Introduction

This instruction manual refers to the Interface range of load pins and includes instructions for both cabled and telemetry options. Before installing or operating any Interface load pin, this and any reference documents, should be read and understood.

These instructions must be retained and incorporated in the technical documentation for the machine or partly completed machinery into which the load pin is installed.

Markings CE

Each load pin will be marked with an individual serial number, CE label and the SWL (safe working load) of the load pin. The load pin will also be marked with an arrow depicting the direction of load acting on the center of the pin.

Electromagnetic Compatibility (EMC)

The electromagnetic compatibility of the load cell device can only be assessed in conjunction with the entire installation, including its control systems. The machine builder who installs this partly completed machinery into a machine is responsible for compliance with the EMC directive.

Load Pin Type/Model Number

- WTSLP *Wireless Stainless Steel Load Pin*
- LP *Wired Stainless Steel Load Pin*

Supplier:

Interface Inc.
7401 East Butherus Drive
Scottsdale, AZ 85260

Tel: (480)948-555
Fax: (480)948-1924
email: contact@interfaceforce.com

Service:

(Repair, Support)
Interface Inc. (address as above)

Installation and Operation

To ensure safe and trouble free installation of the load pin measuring device, the load pin must be properly transported and stored, professionally installed and commissioned.

Unpacking

Before removing the load pin, inspect the packaging for signs of damage and immediately inform the supplier if any damage is found. Unpack the load pin carefully, taking special care with cables and be aware to the possibility of damaging low range devices by mishandling. Ensure that calibration and instruction information is not inadvertently discarded.

Checks Prior to Installation

- If the load pin is fitted with a cable and gland, check that the cable is held securely by the gland.

Operator Instructions for Load Pins

- If the load pin is fitted with a connector, check the connector is secure to the pin, check the plug and socket for any damage and check that the connector mates correctly.
- Check the cable for damage, such as cuts or abrasions, especially where the cable enters the gland or connector assembly.
- Check that all parts (as defined by the general arrangement drawing); cable assembly, anti-rotation bracket, split pins, nuts, washers, spacers, bobbins etc. are present.
- If the load pin is fitted with a telemetry module, check that the 2 off AAA batteries are correctly installed, that the two RED clips on the telemetry housing are closed and that the battery cover is secure.

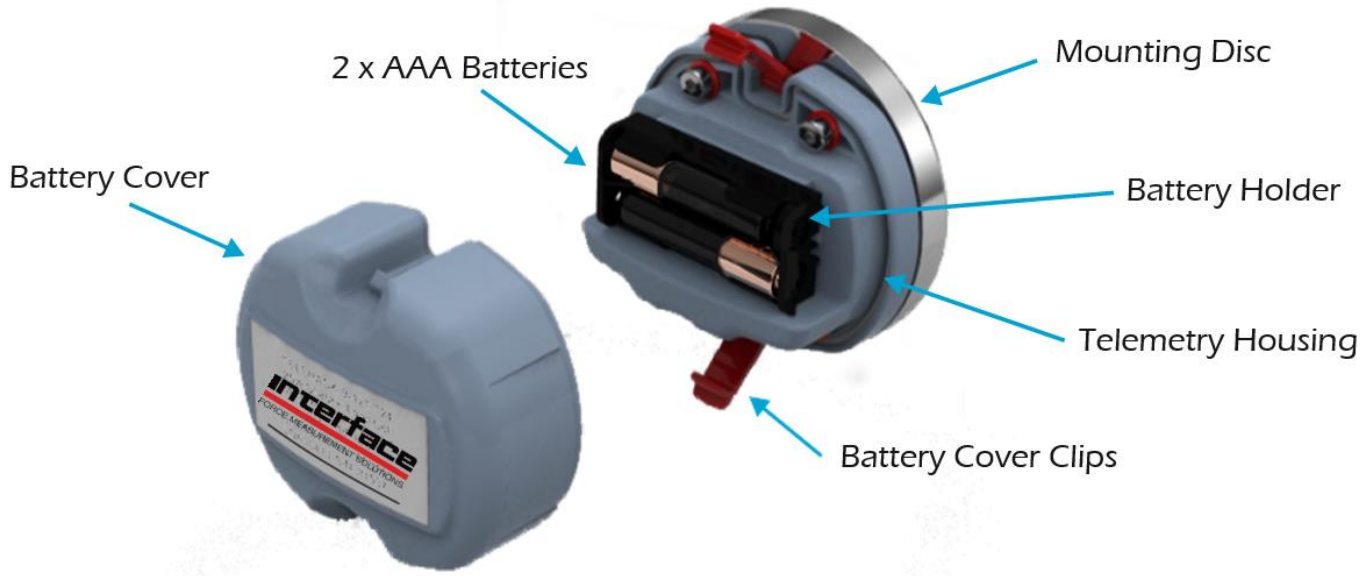

FIGURE 1

Installation

When installing a load pin various factors need to be considered which can influence the performance or accuracy of the load pin. The fit of the pin within a structure is important to the overall performance of the load pin. For an optimal performance, an H7/g6 clearance would normally be recommended, however this is not always achievable in the field and some slight loss of repeatability and linearity can normally be tolerated to achieve an “easy to fit” requirement.

To avoid damage or loss of accuracy during installation the following points should be followed:

- Ensure the load direction arrow on the load pin (usually on the head of the pin) is aligned with the direction of load.
- Ensure the pin is held captive to prevent movement in use by using a keeper plate/locking system. A load measuring pin needs to be securely locked into position in order to fix its orientation with respect to its associated assembly. This needs to be fixed in both the axial and rotation modes to ensure that accurate and repeatable results are obtained from the system.
- If the load pin is fitted with a telemetry unit then ensure that a clear line-of-sight between the transmitter and receiver is maintained, and that objects or structures are kept at least one meter away from antennae wherever possible.
- If the Load Pin is fitted with a telemetry module, the installer should first read the Telemetry User Manual which can be found at the following web address: <https://www.interfaceforce.com/product-category/wireless-telemetry-system/>
- Ensure that both the support plates and the centered plate (or sheave) do not bridge the grooves on the load pin. See Figure 2 for example of correct positioning.
- Ensure that the support plates are not miss-aligned as this will induce bending moments on the load pin which will adversely affect performance.

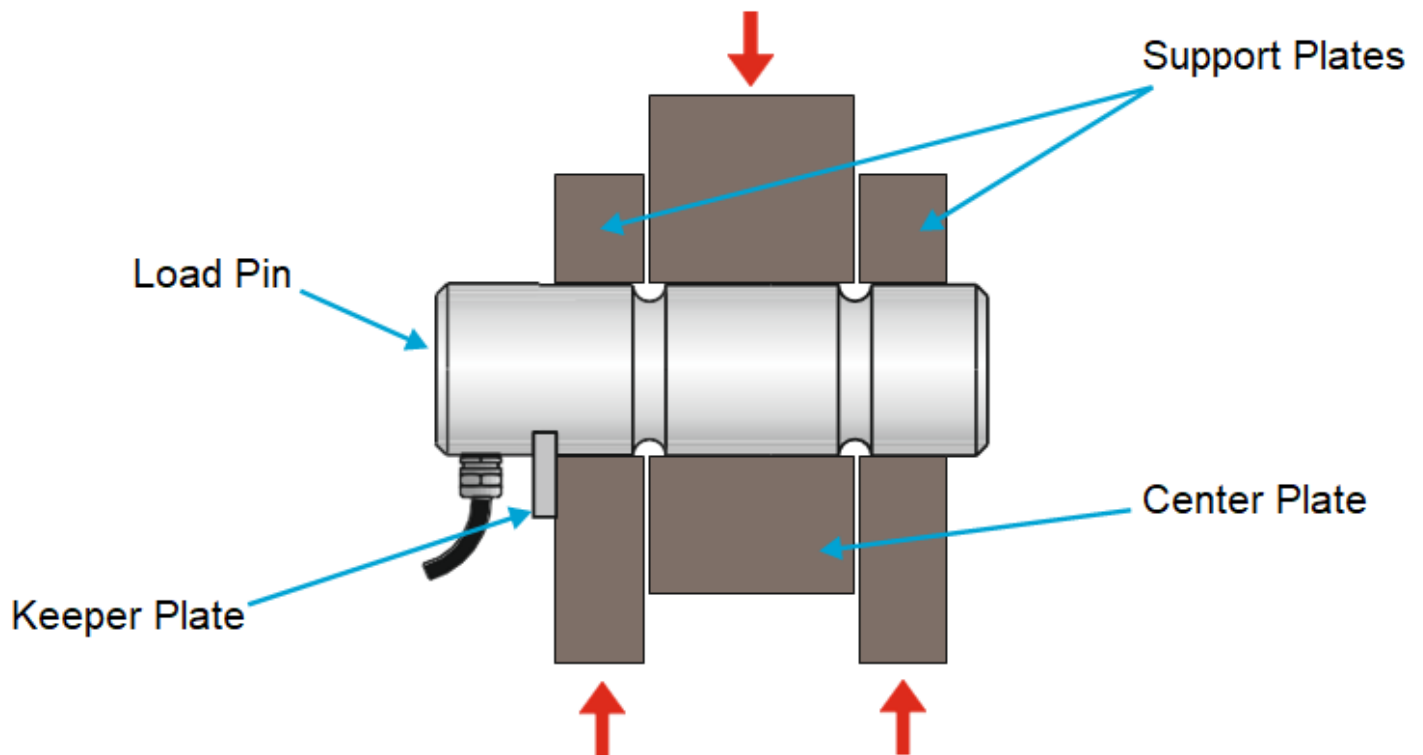

FIGURE 2

Wiring and Electrical Checks

The correct connection of the load pin to an instrument is critical to achieving and maintaining its performance and reliability:

- Wiring connections are given on the calibration certificate supplied with each load pin.
- Where a screened cable is fitted, that screen should be connected as indicated in the manual for the instrument the load pin is connected to.
- Cable length should not be added or removed from the load pin, as this could alter the calibration figures.
- Cable length should not be added or removed from the load pin, as this could alter the calibration figures.
- Where junction boxes are used, check the connections are good quality and securely connected. Clean the enclosure and check that it is free from moisture.
- Load pin cabling must be kept away from high power cables and equipment, high output RF equipment, inductive loads and generators. **Cables must not be run alongside power cables.**

Load Pin Output

The electrical output of the load pin should only be connected to instrumentation with a high enough input impedance, preferably 1Mohm or greater, in order to prevent loading effects on the output sensitivity of the load pin. Interface offers a wide range of digital and analog instruments ensuring compatibility. When setting up your load pin, the following points should be acknowledged:

- The zero load output given on the calibration certificate is the output of the load pin when no load is applied. This includes the removal of the load caused by any lifting accessories.

Operator Instructions for Load Pins

- The load on an installed load pin will comprise of the weight of your assembly (including sheaves, ropes, hook block, drums etc.) and the active load. Therefore, the output with no active load will be greater than the zero output indicated on the calibration certificate.
- The output from the load pin can be in various forms, 4-20mA, 0-10V, mV/V etc. See the calibration certificate for details.

Checks after Installation

With the load pin installed check the pin output is not negative, as this may indicate the pin is incorrectly mounted or subject to miss-alignment forces. Refer back to Installation section for details on correct positioning. Use the calibration certificate for reference of correct output at certain loads..

When applying load to the pin, the output should increase. If this is not the case then check the following:

- a) The grooves are not being bridged by either the support plates or the loaded plate, sheave, etc. If a connector is fitted, ensure that it is fully mated.
- b) Check all electrical connections are correct i.e. to an instrument or a junction box etc.
- c) Check that the load arrow shown on the pin is aligned in the direction of the load acting on the center of the pin.

Calibration

All Interface load pins are calibrated in traceable test machines, configured to best simulate normal loading conditions.

We endeavor to match the loading conditions that would be experienced in service, but it is not possible to totally simulate the on-site structure for every load pin manufactured. For this reason, and optimum system accuracy, calibration in the final assembly is recommended. On-site calibration should be performed in accordance with the manual for the instrument to which the load pin is connected to.

Warnings/Hazards

Load pins are highly stressed devices, and commonly have safety factors between three and five times the rated capacity under static conditions. Fatigue applications and environmental factors can contribute to reducing this margin. The user should determine the effect of any substance to the exposed load pin materials. Where a corrosive environment is present, load pin pins can often be manufactured from corrosion resistant materials, or alternatively, isolation barriers can be employed between the corrosive environment and the load pin pin.

The following points should be followed to avoid potentially hazardous situations:

- Do not weld near to installed load pins. Leakage currents may destroy the load pin pins circuits.
- Load pin pins are sealed units and must not be dismantled. Damaged load pin pins should be returned to Interface for any repairs and re-calibration.
- The accuracy of the system is dependent upon the correct installation of the load pin.
- Load pins must not be handled or carried by the cable.
- Large pins incorporate special lifting accessories. These should only be used as directed in the manufacturer's instructions.
- Load pins must not be subjected to shock loads, such as using a hammer to force the pin into position.
- The load pin must never be placed in a potentially explosive environment, unless the product is suitably certified (ATEX or IECEx).
- Fixing methods – keeper plates, split pins, washer and nuts must always be correctly installed. Pin material and any applied treatments (heat treatments etc.) should be verified as suitable for the environment before the load pin is installed. If in doubt about the suitability of a product, please contact Interface for advice.

Operator Instructions for Load Pins

Inspection and Repair

Repair

Only Interface personnel are authorised to carry out a repair or service to their products. All repairs or services will be carried out in the premises of Interface. The unit is not serviceable outside of Interface premises.

Inspection

All Interface load pins should be subject to periodic inspection, which should include, but is not exclusive to the following checks:

- Completion of the checks after installation.
- Check output at zero load (shift in zero offset). Verify against calibration certificate.
- Inspect to see if the load pin has been damaged/worn or chemically attacked (from a corrosive environment or lubricants etc.).
- For cabled versions, verify the integrity of the cable.
- After any serious operating incident, repeat first four checks above.
- For load pins fitted with a telemetry module, check that the batteries are correctly installed. The battery holder shows pictorially the correct orientation.
- For load pins fitted with a telemetry module, check for any signs of water ingress to the battery compartment and for any battery corrosion.
- In the unlikely event of this device failing, fit new batteries (if applicable) and re-test. Only when this has been done should you report the fault. When reporting the fault, give a full description of the problem and the type of application the device is being used for.

Load Pin Specification

All Load Pins have datasheets that can be found in the follow web address:

<https://www.interfaceforce.com/product-category/wireless-telemetry-system/>

Cable Gland and Connector Configurations

All cable gland wiring colors or connector pin details are shown on the Calibration Certificate supplied.

The removal or replacement of the cable gland or bulkhead connector or any adjustment or repair must either be performed by Interface or by a suitably qualified and approved engineer.

Examples of cable gland and connector arrangements:

Operator Instructions for Load Pins

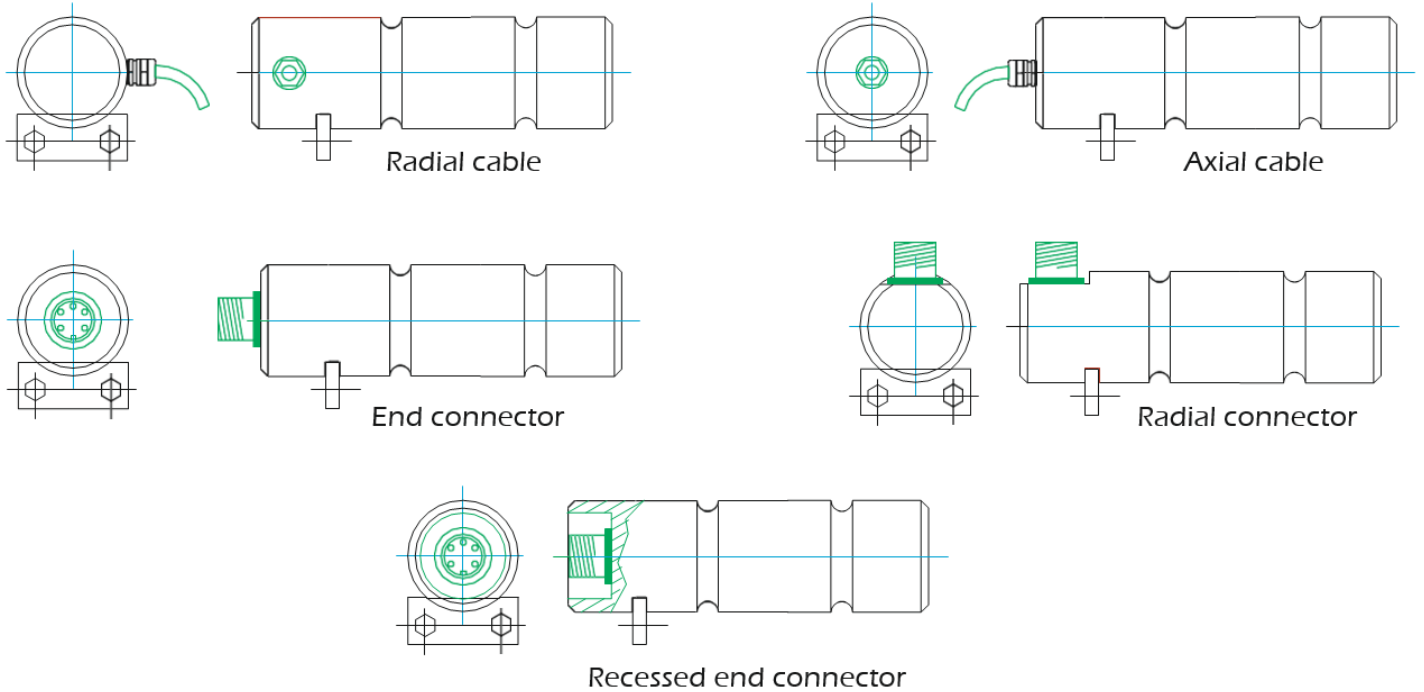

FIGURE 3

Mating Connector Assemblies

- Check both halves of the connector for any damage or obstructions.
- Align the connector assembly and mate the two halves. Press firmly to ensure they are fully engaged.
- Tighten the locking sleeve. Finger tight is enough to complete the mating process.
- Always fully disengage the locking sleeve before attempting to de-mate the connector.

Load Pin Locking System Configurations

Each load pin is supplied with a locking and anti-rotation system which secures the position and orientation of the load pin, which are critical to its correct operation.

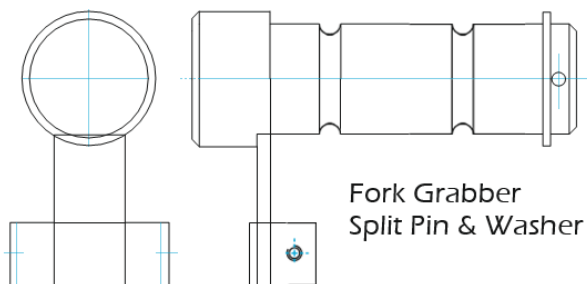

Operator Instructions for Load Pins

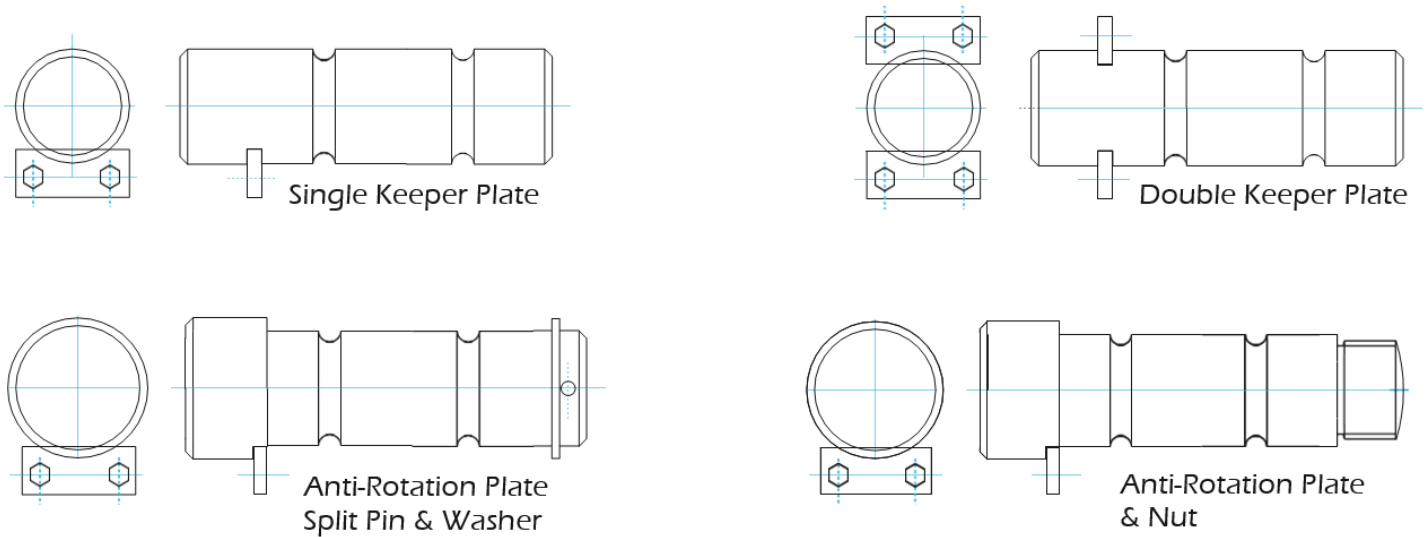

Installing a Locking and Anti-Rotation System

There are numerous variations of locking and anti-rotation methods for a load pin. The examples show the most common methods and show that locking and anti-rotation can be achieved using dual systems (anti-rotation plate, split pin and washer etc.).

The example below shows a common anti-rotation/locking plate system (also known as a keeper plate). To correctly install a keeper plate, appropriately sized retaining bolts should be fitted through the holes provided and screwed into tapped holes in the mating assembly.

In the example below the holes have been drilled to accommodate M6 bolts. The use of the correct size bolts is critical to ensuring the correct orientation of the load pin.

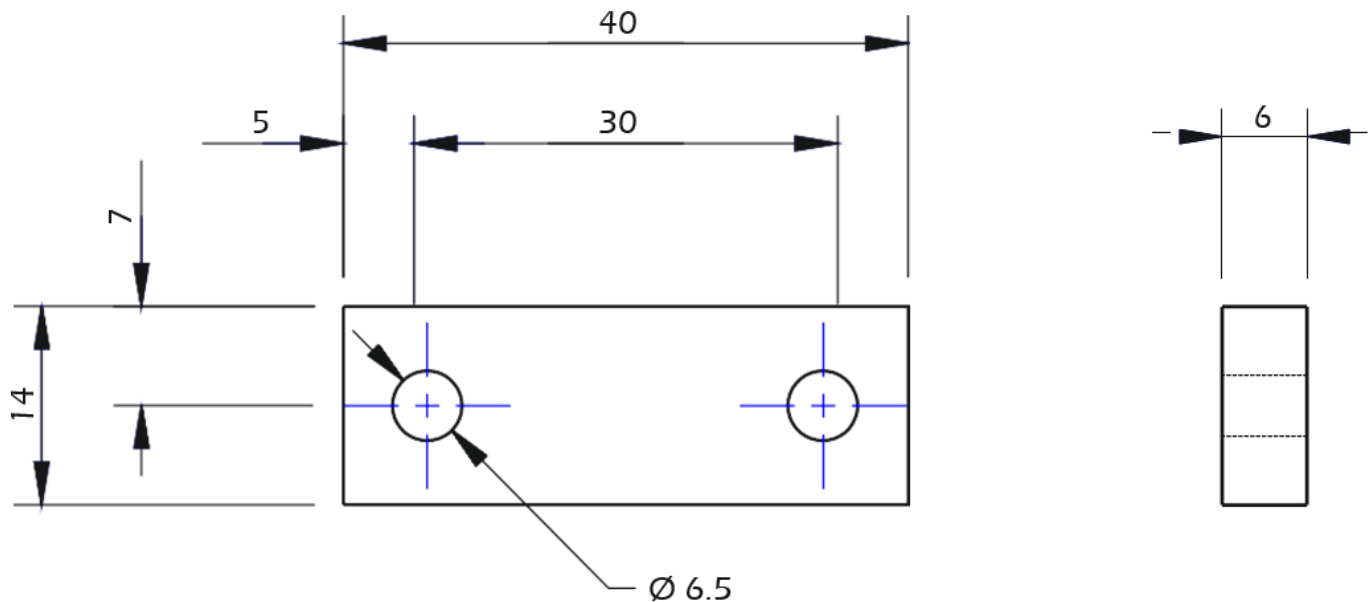

When a load pin is supplied with a threaded end and retaining nut, the nut should only be finger tight. Over tightening of retaining nuts will impact on the functionality of the load pin. Retaining nuts should be secured in position using either a split pin, locking washer, lock nut or circlip.

Operator Instructions for Load Pins

Load Pin Output Options

The load pin can be fitted with a variety of built in (in-cell) signal conditioning pcbs, to offer either analog, voltage, current signals or RS485 digital signals (in various protocols). When a wireless signal is required, the load pin pin can be fitted with a WTS-BS-1 Telemetry Module.

Telemetry

The WTS product range uses high performance two-way radio communication. Each load pin fitted with the telemetry module requires either a WTS-BS-1-HA handheld device, digital/analog interface or a base station and PC to communicate with.

Warranty

All Telemetry products from Interface Inc., ('Interface') are warranted against defective material and workmanship for a period of (1) one year from the date of dispatch. If the 'Interface' product you purchase appears to have a defect in material or workmanship or fails during normal use within the period, please contact your Distributor, who will assist you in resolving the problem. If it is necessary to return the product to 'Interface' please include a note stating name, company, address, phone number and a detailed description of the problem. Also, please indicate if it is a warranty repair. The sender is responsible for shipping charges, freight insurance and proper packaging to prevent breakage in transit. 'Interface' warranty does not apply to defects resulting from action of the buyer such as mishandling, improper interfacing, operation outside of design limits, improper repair or unauthorized modification. No other warranties are expressed or implied. 'Interface' specifically disclaims any implied warranties of merchantability or fitness for a specific purpose. The remedies outlined above are the buyer's only remedies. 'Interface' will not be liable for direct, indirect, special, incidental or consequential damages whether based on the contract, tort or other legal theory. Any corrective maintenance required after the warranty period should be performed by 'Interface' approved personnel only.

Revision History		
Author	Revision	Release Date
PB	A	09/12/2018