

# 4-Channel PC Interface Module and Data Acquisition Instrument BSC4D



BSC4D-D  
BSC4D-BT

Operating Manual

Released June 20, 2023



## Table of contents

Strain gage measuring amplifier BSC4D.....	5
Description .....	5
Dimensions .....	6
Technical data.....	7
Connection assignment.....	8
Strain gage measuring amplifier BSC4D-BT .....	23
Description .....	23
Dimensions .....	24
Technical data.....	25
Wiring diagram.....	26
Technical data BSC4D-BT M12.....	30
Switch configuration BSC4D-BT M12 .....	32
Measurement resolution.....	34
Order variants BSC4D-BT .....	35
Programming / configuration.....	36
Scaling of measured values.....	36
Measuring range 2.0 mV/V.....	36
Measuring range 10.0 mV/V .....	36
Measuring range 0.0 to 5 V.....	37
Measuring range 0.0 to 10 V .....	37
Measuring range PT1000.....	37
Measuring range K thermocouple cable .....	38
Commands for configuration .....	38
List of commands.....	38
Description of commands .....	41
Protocol for measured values .....	43
Protocol for commands .....	44
Protocol for responding to commands.....	44
Digital IOs.....	45
analog input.....	50
CAN bus.....	51
Protocol for measured values .....	51
Protocol for commands .....	51
Protocol for responding to commands.....	51
Configuring the CAN-ID .....	52
Data frequency and filter.....	54
analog filter.....	54
Digital filter.....	54

Annex .....55  
    Connection figures for BSC4D-BT SD and BSC4D-BT LD .....55  
    Warranty.....58

## Strain gage measuring amplifier BSC4D-D



BSC4D-C M12 Connectors  
Front view sensor connection



BSC4D-D D37-Pin D-Sub  
Front view sensor connection

- 4-channels
- Power supply via USB port
- Inputs for Strain gage / 0–10 V / PT1000
- Measurement ranges 2 mV/V / 10 mV/V
- Strain gage quarter / half / full bridges
- 8 digital inputs / outputs

### Description

This 4-channel measuring amplifier for sensors with strain gages is equipped with a USB interface. The measuring amplifier can be delivered with an 37-pin D-Sub connection or with 4x M12 ports. The measuring amplifier has eight digital inputs and outputs.

On the backside 25-pin D-Sub socket, strain gage full-bridges and half-bridges 120 Ohm up to 1 kOhm as well as PT1000 temperature sensors and 1000 Ohm single grid strain gages or voltages 0 ... 5V can be connected.

The front-end M12 socket is configured by default for strain gage full-bridge connections and for voltage inputs 0 ... 5V and 0 ... 10V.

## Dimensions

Figure 1: Dimensions BSC4D-D 37-pin D-Sub

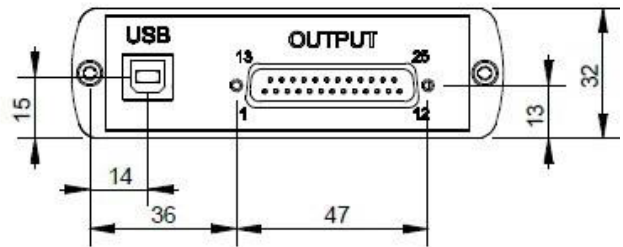
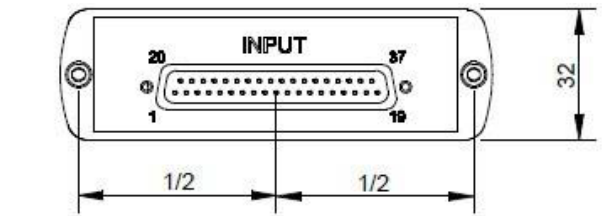
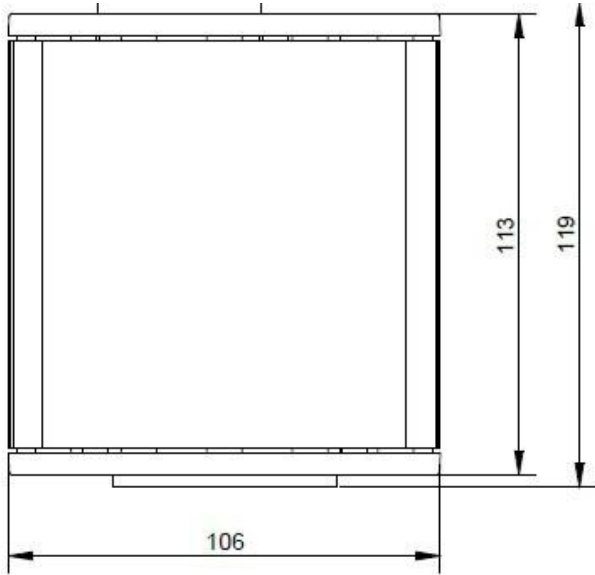
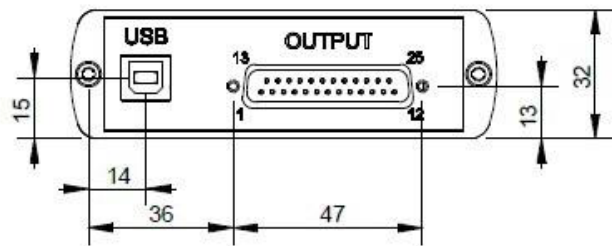
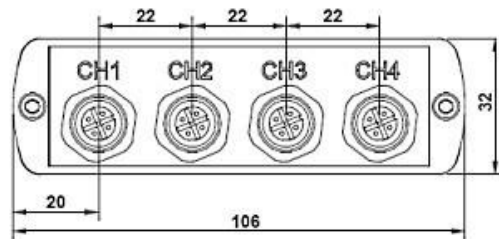
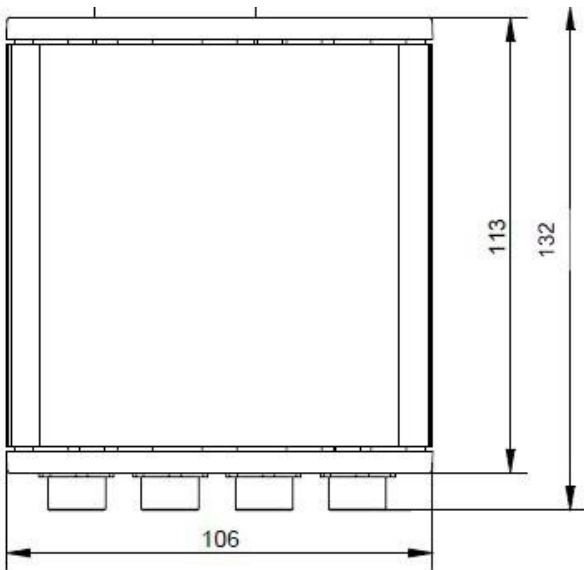

Figure 2: Dimensions BSC4D-C M12



## Technical data

Accuracy class	0.05	%
<b>Inputs</b>		
Resolution	16	Bit
Strain gage inputs		
Full bridge	89-5000	Ohm
Half bridge	89-5000	Ohm
Quarter bridge	120 / 350 / 1000	Ohm
Common mode rejection		
at 60 Hz common-mode signal	95–110	dB
<b>Measurement frequencies</b>		
Data frequency	0 – 500	Hz
Sampling frequency	1.92	MHz
Cut-off frequency		
analog	450	Hz
digital	Notch filter	Hz
<b>Outputs</b>		
Bridge supply voltage	2.5	Volt
Current load capacity	30	mA
Fixed voltage output	5	V
Current load capacity	20	mA
Switching outputs/inputs	TTL level	
I/O 1-8	5 (active High)	V
Current load capacity:	5	mA
Interface	USB 1.1, USB 2.0 compatible	
Supply voltage		
Nominal range	4.5... 5.5 via USB port	VDC
Isolation voltage	1000	Vrms
Current consumption	< 200	mA
<b>Temperature range</b>		
Nominal temperature range	-10...+65	°C
Storage temperature range	-40...+85	°C
Zero point drift	< 0.05	%/10°C
Sensitivity drift	< 0.01	%/10°C
<b>Dimensions</b>		
L x W x H	106 x 119 (132) x 32	mm x mm x mm
<b>Protection type / Weight</b>		
Protection type	IP40	

Weight BSC4D-D 37-pin D-Sub	239	g
-----------------------------	-----	---

Table 1: Technical data BSC4D-D

Connection assignment

Connection plan for 37-pin D-sub port

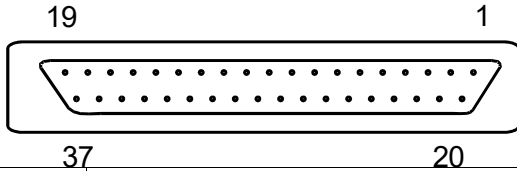

	BSC4D-D assignment	37-pin D-sub port (PIN No.)			
		Channel 1	Channel 2	Channel 3	Channel 4
+US	positive sensor supply	20	2	11	29
+UD	positive differential input	22	4	13	31
QB1000	quarter bridge extension 1kOhm	23	5	14	32
HB	half bridge extension	24	6	15	33
-UD	negative differential input	25	7	16	34
-US	negative sensor supply	27	9	18	36
UE	analog input	28	10	19	37
	screen	1	1	1	1

Table 2: analog inputs

Connection assignment for BSC4D-C M12

5-pin port M12x1, type 763

Top view:



5-pin	Description	Color code for cables
2	-US negative bridge supply	white
1	+US positive bridge supply	brown
3	+UD positive differential input	blue
4	-UD negative differential input	black
5	AUX in input without cable	grey



Connection of full bridge with BSC4D-D 37-pin D-Sub version

The following graphics show the connection of a full bridge to channel 1 through to channel 4.

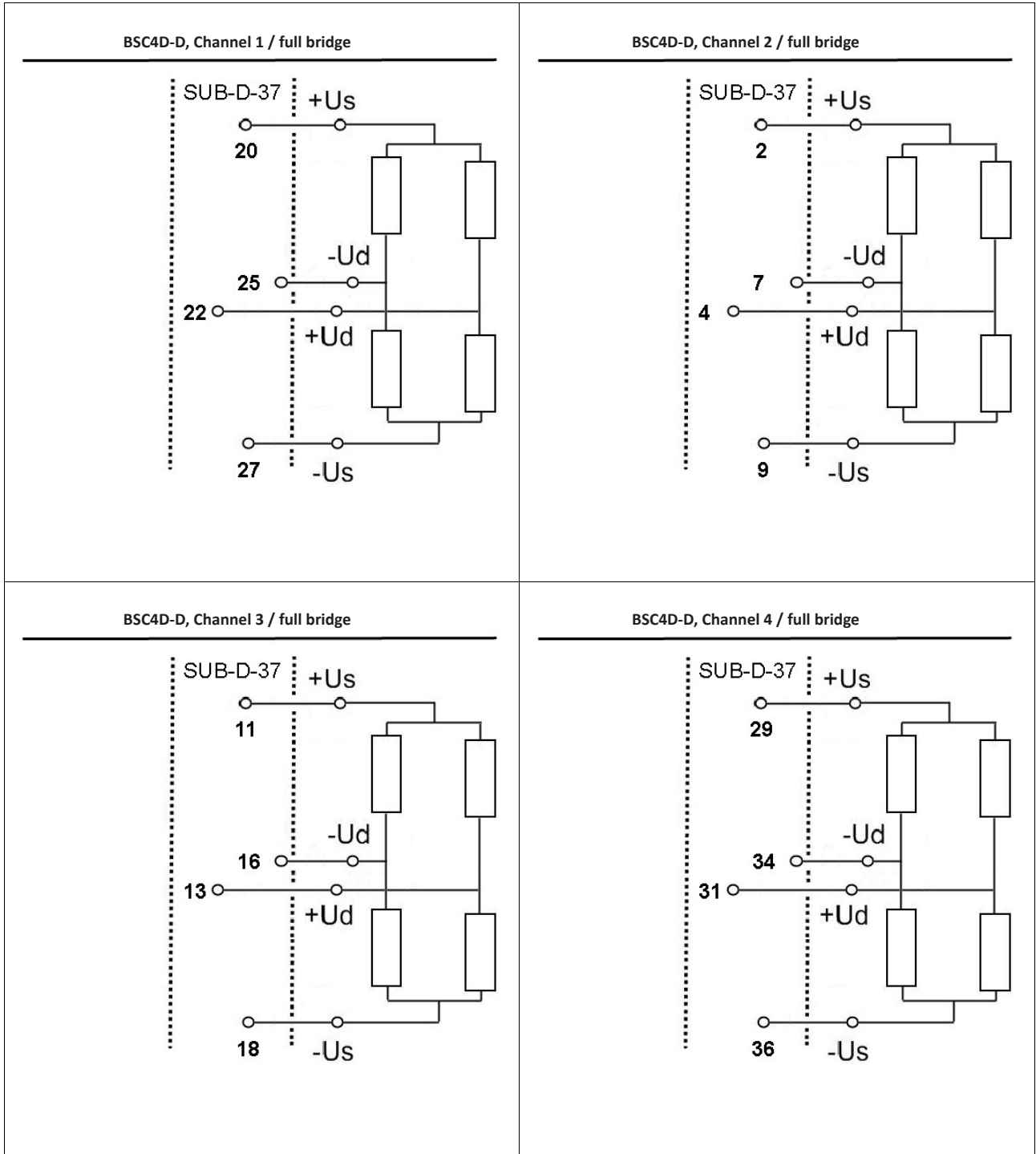

Connection of half bridge with BSC4D-D 37-pin D-Sub version

The following graphics show the connection of a half bridge to channel 1 through to channel 4.

The bridge extension should be adapted depending on the application.

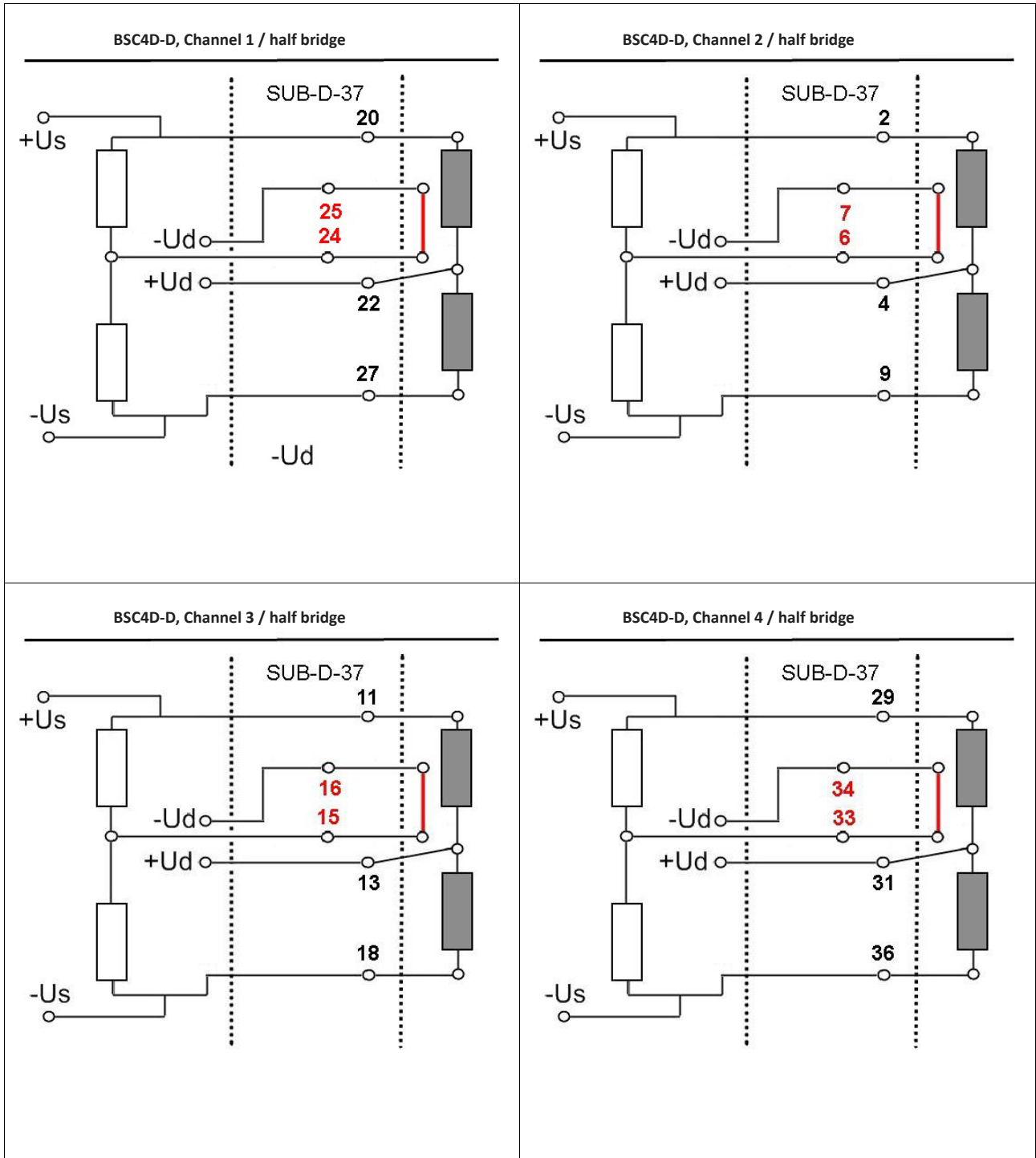

Connection of quarter bridge with BSC4D-D 37-pin D-Sub version

The following graphics show the connection of a quarter bridge to channel 1 through to channel 4.

The bridge extension should be adapted depending on the application.

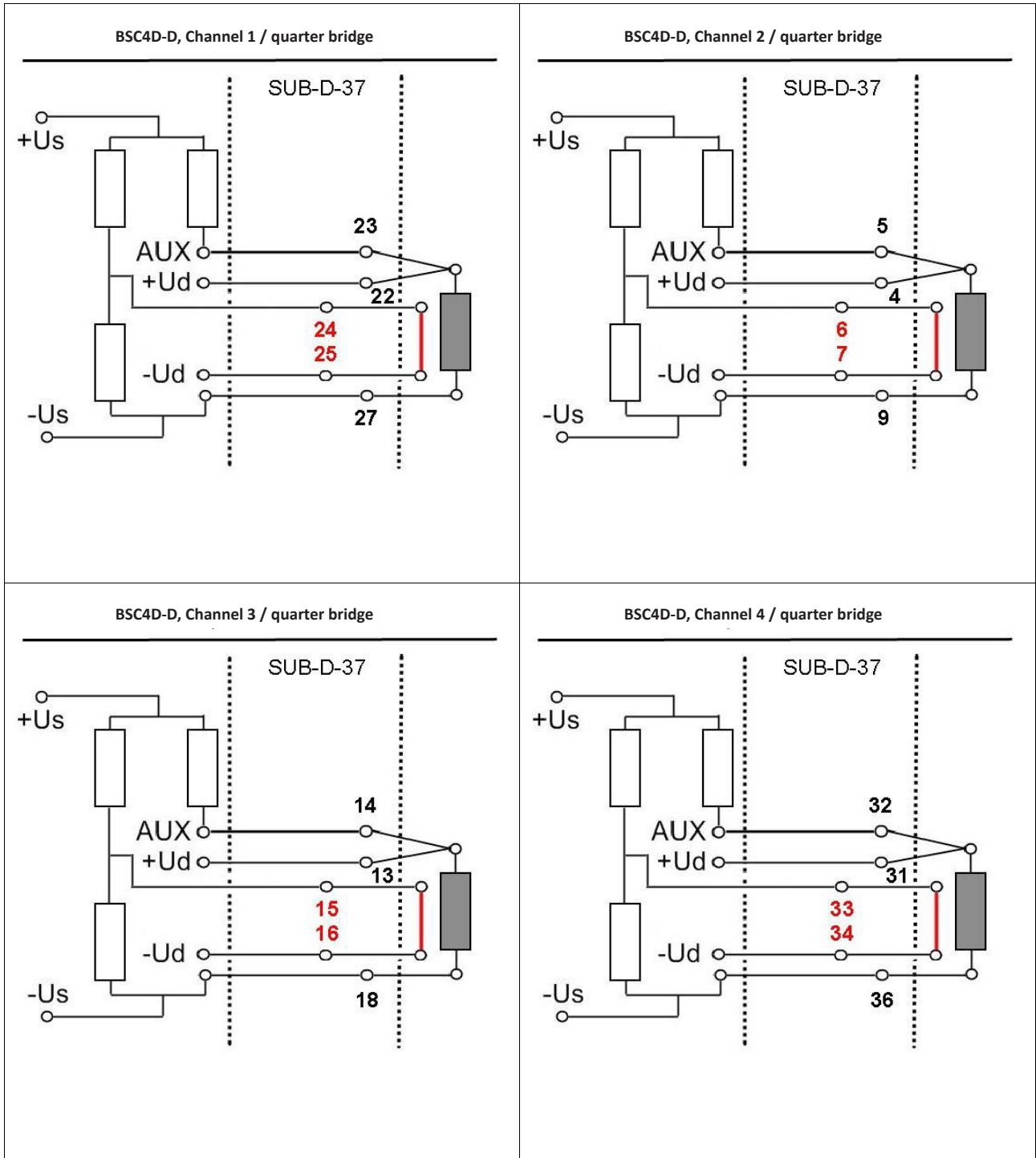

Connection of full bridge with BSC4D-C M12 version

The following graphic shows the connection of a full bridge for the M12 version.

BSC4D-C, full bridge | M12

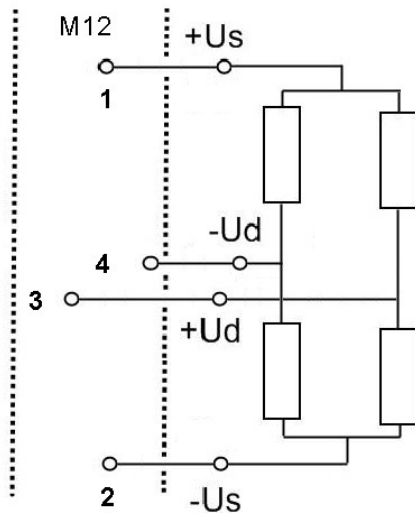

Connection of half bridge with BSC4D-C M12 version

The following graphic shows the connection of a half bridge for the M12 version. The bridge extension should be adapted depending on the application.

BSC4D-C, half bridge | M12

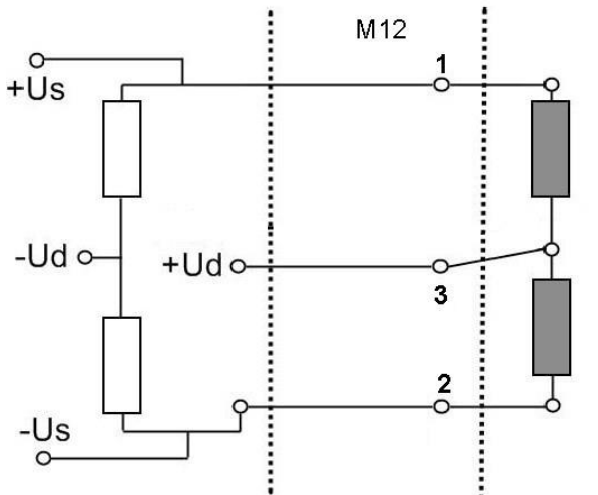

■ HB1

Please close the jumper on the printed circuit board

Please set the solder bridges:

- HB1 when using channel 1 with a half bridge.
- HB2 when using channel 2 with a half bridge.
- HB3 when using channel 3 with a half bridge.
- HB4 when using channel 4 with a half bridge.

Solder bridges: Figure 3: Solder bridges for configuring bridge extensions see page 11

### Connection of quarter bridge or PT1000 with M12 version

The following graphic shows the connection of a quarter bridge for the M12 version. The bridge extension should be adapted depending on the application.

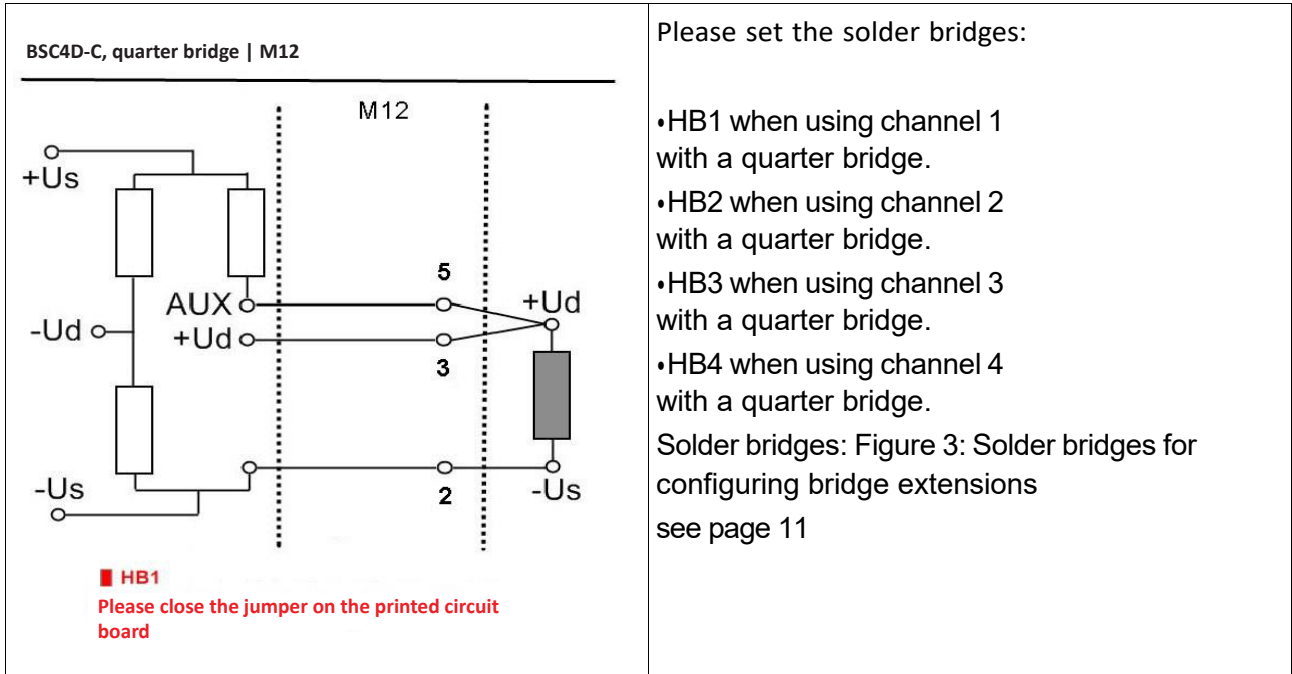

### Adaptation of the bridge extension for BSC4D Opening the device

1. Remove both screw covers from the input side and remove the fastening screws from the front cover.
2. The two hexagonal bolts on the 37-pin D-Sub port must be loosened using a socket spanner (5 mm).
3. The printed circuit board is pulled out on the side of the 25-pin D-Sub port.

### Adaptation of the bridge extension with M12 version

The bridge extension can be individually adapted for each channel, for this purpose the device must be opened and, according to the following figures 1 - 5, the desired soldering bridge must be added. For PT1000 probes, the additional resistance 1kOhm is selected.

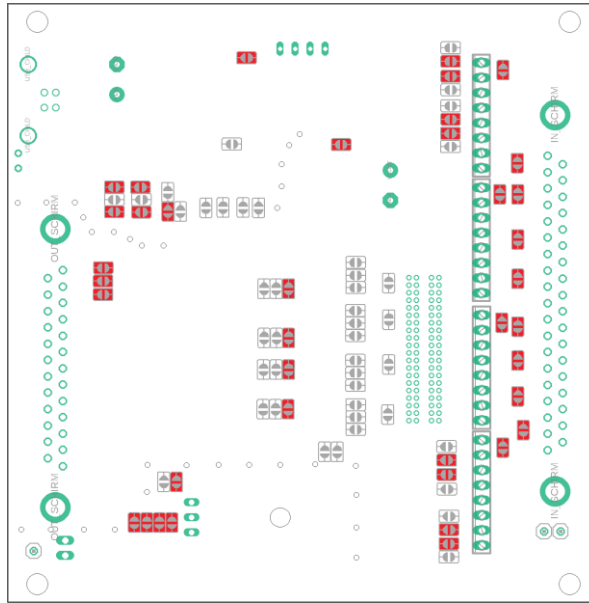

Figure 1: M12\_standard variant

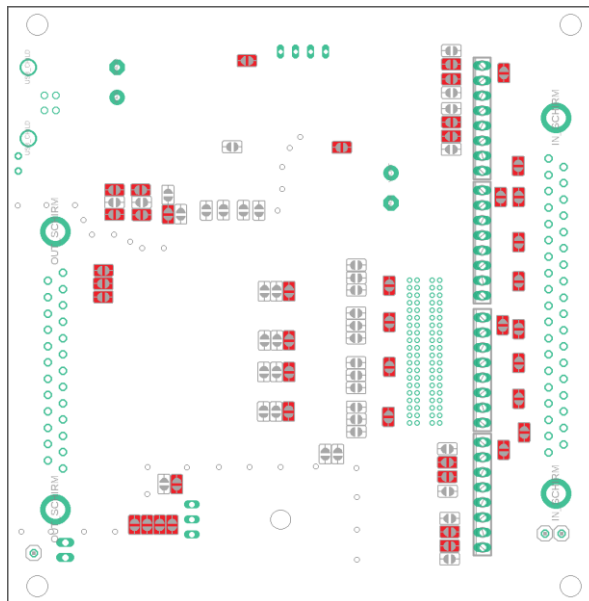

Figure 2: M12\_half bridge

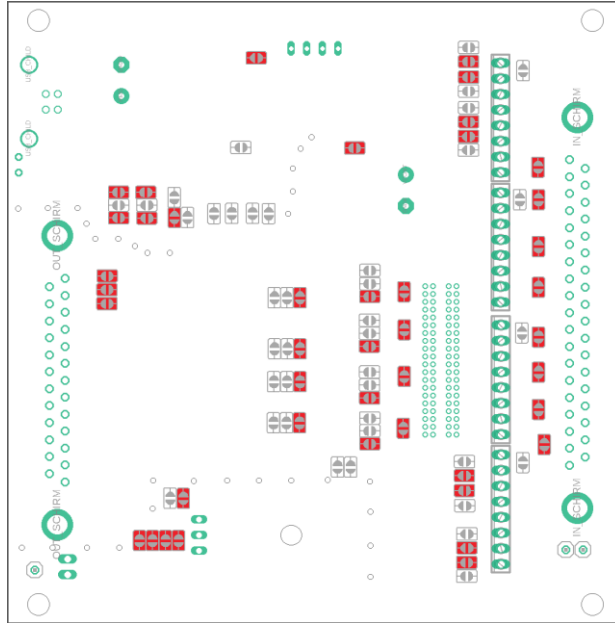

Figure 3: M12 quarter bridge 1kOhm

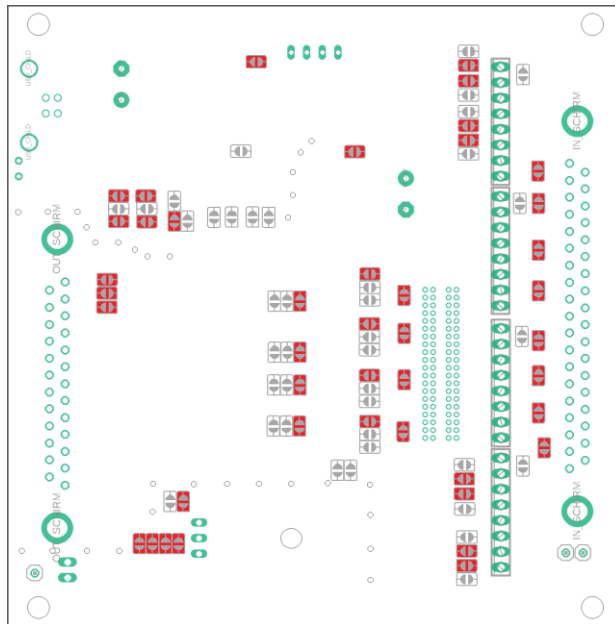

Figure 4: M12 quarter bridge 350Ohm

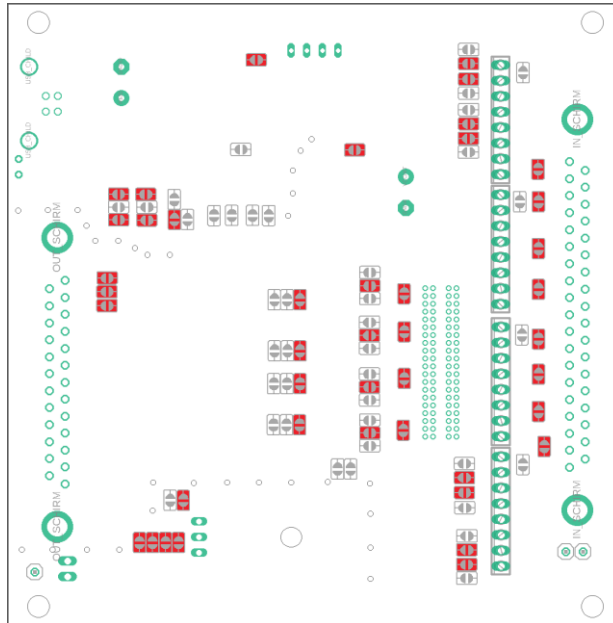

Figure 5: M12 quarter bridge 120Ohm

The following table explains the configuration options according to the figures already shown.

Image, Configuration	Plug Connector	Full bridge	Half Bridge	Quarter-Bridge 350 Ohm	Quarter-Bridge 120 Ohm	Quarter-Bridge 1000 Ohm
M12 Standard variant	M12	yes	no	no	no	no
M12 Half Bridge	M12	no *	yes	no	no	no
Quarter Bridge 350Ohm	M12	no *	yes	yes	no	no
Quarter Bridge 120Ohm	M12	no *	yes	no	yes	no
Quarter Bridge 1kOhm	M12	no *	yes	no	no	yes

\* Measurement of a full bridge with active half-bridge is possible, but is carried out with a measurement error



Adapting the bridge extension with Sub-D37 version

The bridge extension can be adapted individually for each channel, for this purpose the device must be opened and, according to the following figures 6 - 8 the desired soldering bridge must be supplemented.

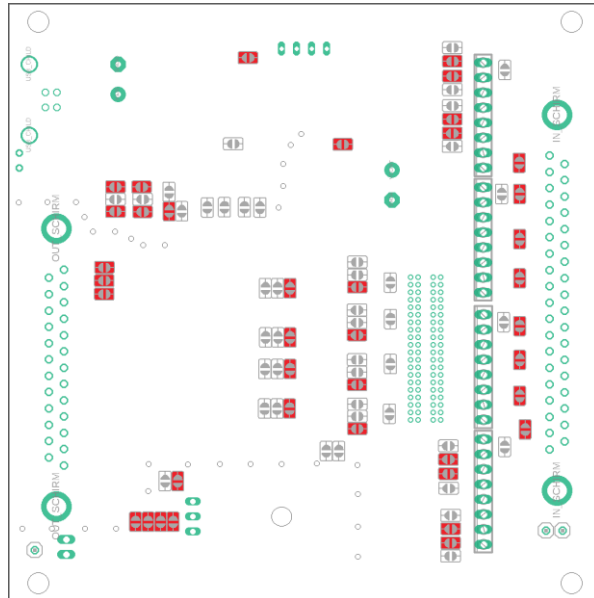

Figure 6: Sub-D37 standard variant

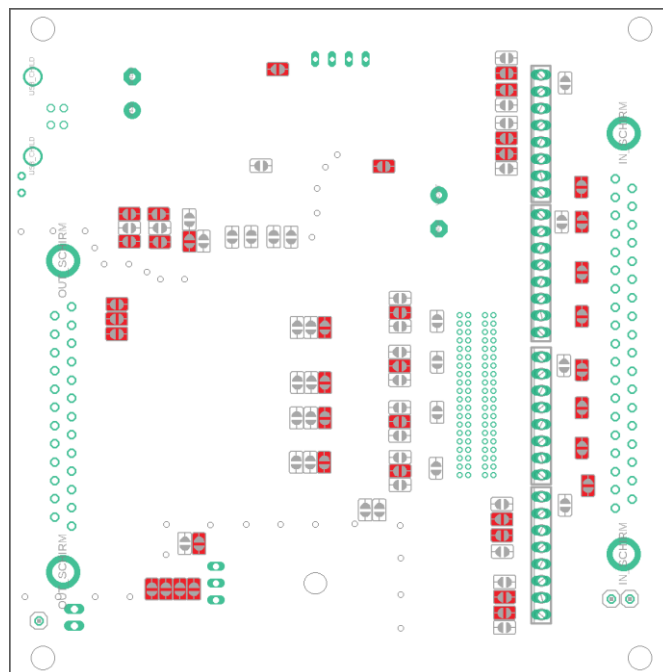

Figure 7: Sub-D37 quarter bridge 120Ohm

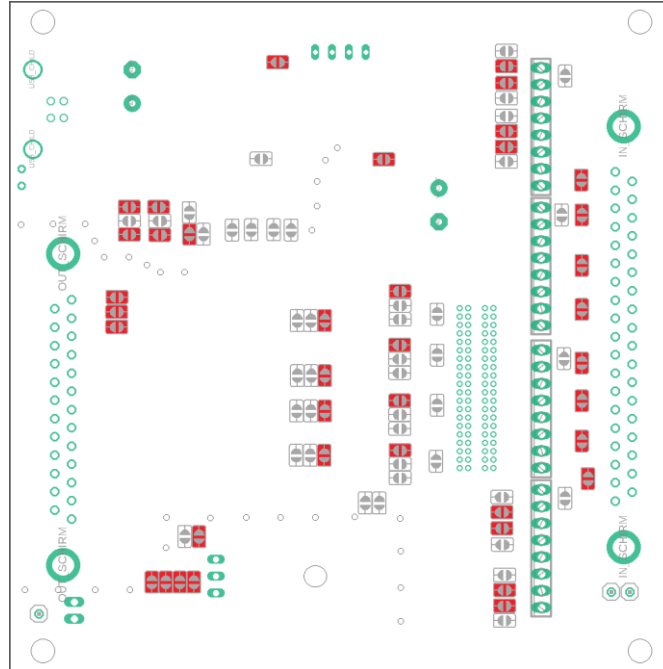

Figure 8: Sub-D37 quarter bridge 350 Ohm

The following table explains the configuration options according to the figures already shown.

Image, Configuration	Plug connector	Full bridge	Half Bridge	Quarter-Bridge 350 Ohm	Quarter-Bridge 120 Ohm	Quarter-Bridge 1000 Ohm	Voltage input
Sub-D37 Standard variant	Sub-D37	yes	yes	no	no	yes	yes
Sub-D37 Quarter bridge 350 Ohm	Sub-D37	yes	yes	yes	no	no	yes
Quarter bridge 120 Ohm	Sub-D37	yes	yes	yes	yes	no	yes

Wiring diagram for position sensors

The measuring amplifier BSC4D must be configured by the manufacturer separately when using it with potentiometric position sensors (linear potentiometers or draw wire displacement sensors) for the M12 version.

The position sensor's wiper is connected to the measuring amplifier's "Aux" input (M12) or "U<sub>E</sub>" (37-pin D-Sub). The position sensor supplies via the sensor supply +U<sub>s</sub> and -U<sub>s</sub>.

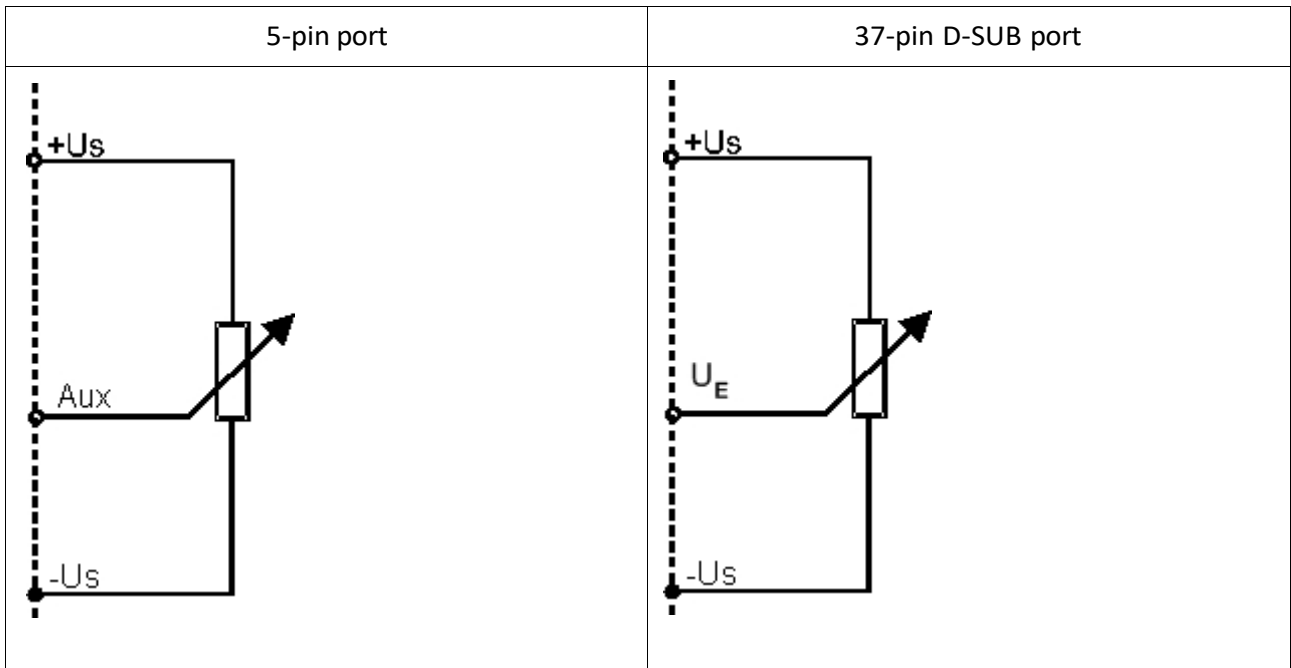

The potentiometric position sensor is supplied with 2.5 V. The "Aux" input or U<sub>E</sub> records voltages of 0...5 V.

Connection assignment

Label	5-pin port	37-pin D-SUB port				
		CH 1	CH 2	CH 3	CH 4	
positive supply +U <sub>s</sub>	1	positive supply +U <sub>s</sub>	20	2	11	29
negative supply -U <sub>s</sub>	2	negative supply -U <sub>s</sub>	27	9	18	36
"Aux" input	5	U <sub>E</sub> input	28	10	19	37

Connection diagram for voltage input 0...5V (0...10V)

The signal to be measured is connected to the input "Aux" (M12) or "U<sub>E</sub>" (37-pin D-Sub) of the measuring amplifier. The signal mass is connected to -US/GND.

The input Aux or U<sub>E</sub> detects voltages of 0...5V (0...10V).

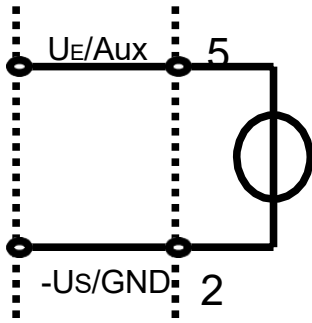

*Drawing 1: 5-pin socket*

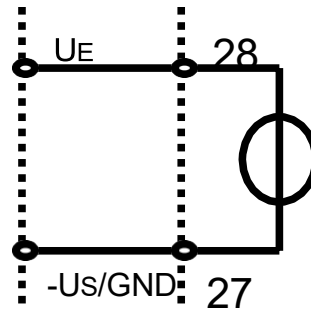

*Drawing 2: 37-pin Sub-D socket, CH 1*

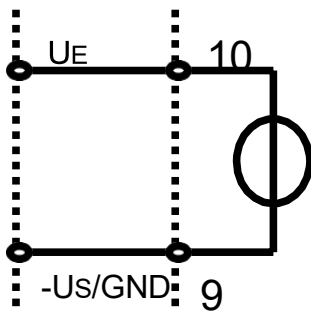

*Drawing 4: 37-pin Sub-D socket, CH 2*

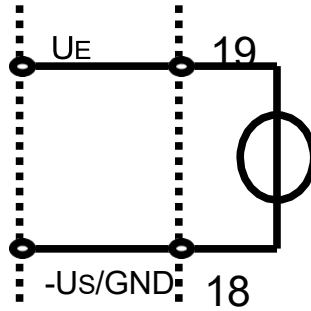

*Drawing 3: 37-pin Sub-D socket, CH 3*

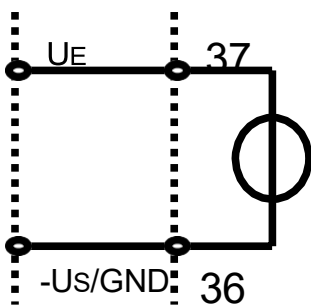

*Drawing 5: 37-pin Sub-D socket, CH 4*

Connection of the Way Con – draw wire sensor SX

4-pin port Waycon draw wire sensor SX	5-pin port	Label	Color code	M12 sensor-actuator cable	
1 (+supply)	1	positive supply +Us	brown		
3 (GND)	2	negative supply -Us	blue		
2 (wiper)	5	“Aux” input	white		
4-pin port Waycon draw wire sensor SX	37-pin D-SUB port				
	CH 1	CH 2	CH 3	CH 4	
1 (+supply)	20	2	11	29	pos. supply +Us
3 (GND)	27	9	18	36	neg. supply -Us
2 (wiper)	28	10	19	37	U <sub>E</sub> input

Connection assignment SUB-D25 port

BSC4D assignment	25-pin D-sub port (PIN-No.)			
IO 5 V fixed voltage output	1			
IO GND	2			
IO 1	3			
IO 2	4			
IO 3	5			
IO 4	6			
IO 5	7			
IO 6	8			
IO 7	9			
IO 8	10			
TX	11			
RX	12			
GND	13			
	Channel 1	Channel 2	Channel 3	Channel 4
GND	14	17	20	23
0...5V Input	15	18	21	24
AUX Input	16	19	22	25

## Strain Gage measuring amplifier BSC4D-BT



Figure 5: BSC4D-BT M12

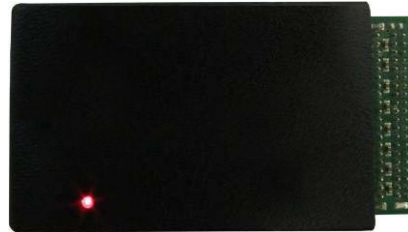

- Bluetooth interface
- 4-channels
- Inputs for Strain gage / 0–10 V / PT1000
- Measurement ranges 2 mV/V / 10 mV/V
- Strain gage quarter / half / full bridges
- 8 digital inputs / outputs
- Data rate 0 Hz–500 Hz

### Description

The measuring amplifier BSC4D-BT is suited to wireless measurement data acquisition with wire strain gage sensors. The BSC4D-BT is suitable for connecting Strain gage full bridges and half bridges. For quarter bridges (120 Ohm, 350 Ohm, and 1000 Ohm), there is a connection option in three-wire technology.

Data is transmitted by radio via the Bluetooth Standard 2.0+EDR with serial port profile (SPP). The range is 20 m in buildings or up to 100 m when in direct line of sight.

Commercial Bluetooth dongles with Widcom or Toshiba drivers which support the “serial- port- protocol” are suitable as receivers.

Data rates are possible from 0 Hz to 500 Hz. They are supplied via e.g. a lithium-polymer battery. By opening the interface for the application software, the module is switched on. Current consumption is less than 150 mA. When not in use, current consumption is under 10 mA. A battery can be charged at 5V supply voltage via an integrated charge regulator. Threshold values or digital outputs can be programmed with the 8 digital outputs

Standard PIN: 0000

Dimensions

BSC4D-BT SD

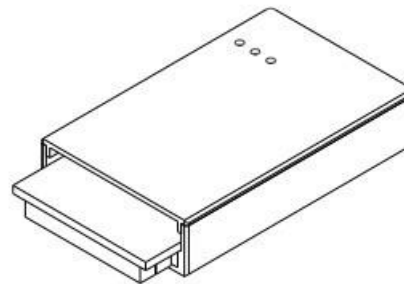
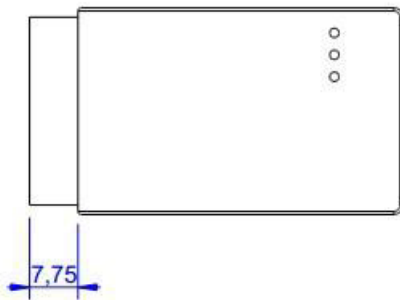
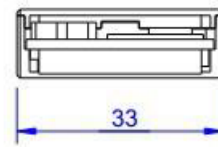
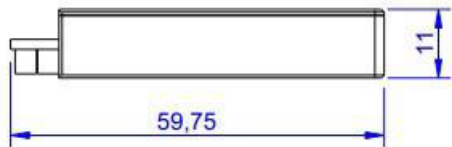

BSC4D-BT LD

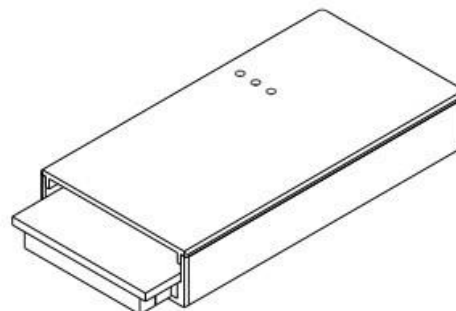
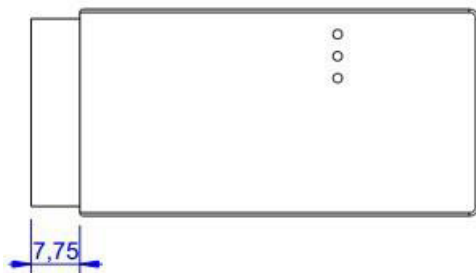
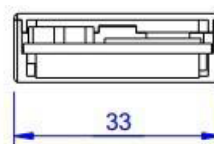
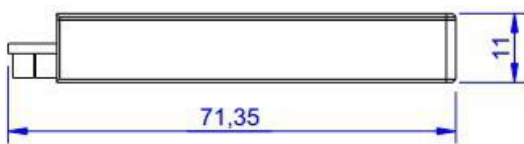



## Technical data

Accuracy class	0.05	%
Inputs		
Resolution	16	Bit
Strain gage inputs		
Full bridge	89-5000	Ohm
Half bridge	89-5000	Ohm
Quarter bridge	120, 350, 1000	Ohm
Common mode rejection at 60 Hz common-mode signal	95–110	dB
Measurement frequencies		
Data frequency	0–500	Hz
Sampling frequency	1.92	MHz
Cut-off frequency		
analog	450	Hz
digital	Notch filter, configurable	
Outputs		
Bridge supply voltage	2.5	Volt
Current load capacity	30	mA
Switching outputs/inputs I/O 1-8	TTL level	
Level	5 (active High)	V
Current load capacity:	5	mA
Interface	Bluetooth Standard 2.0+EDR	
Supply voltage		
Nominal range	3.3...4.2	V DC
Current consumption @ 4.2 V DC	< 150	mA
Charge regulator	5.0 ± 0.5	V DC
Current consumption @ 5.2 V DC	< 450	mA
Temperature range		
Nominal temperature range	-10...+65	-10...+65
Storage temperature range	-40...+85	-40...+85
Zero point drift	< 0.05	%/10°C
Sensitivity drift	< 0.01	%/10°C
Dimensions		
L x W x H	60 x 33 x 10	mm x mm x mm
Protection type		
	IP64	

Wiring diagram

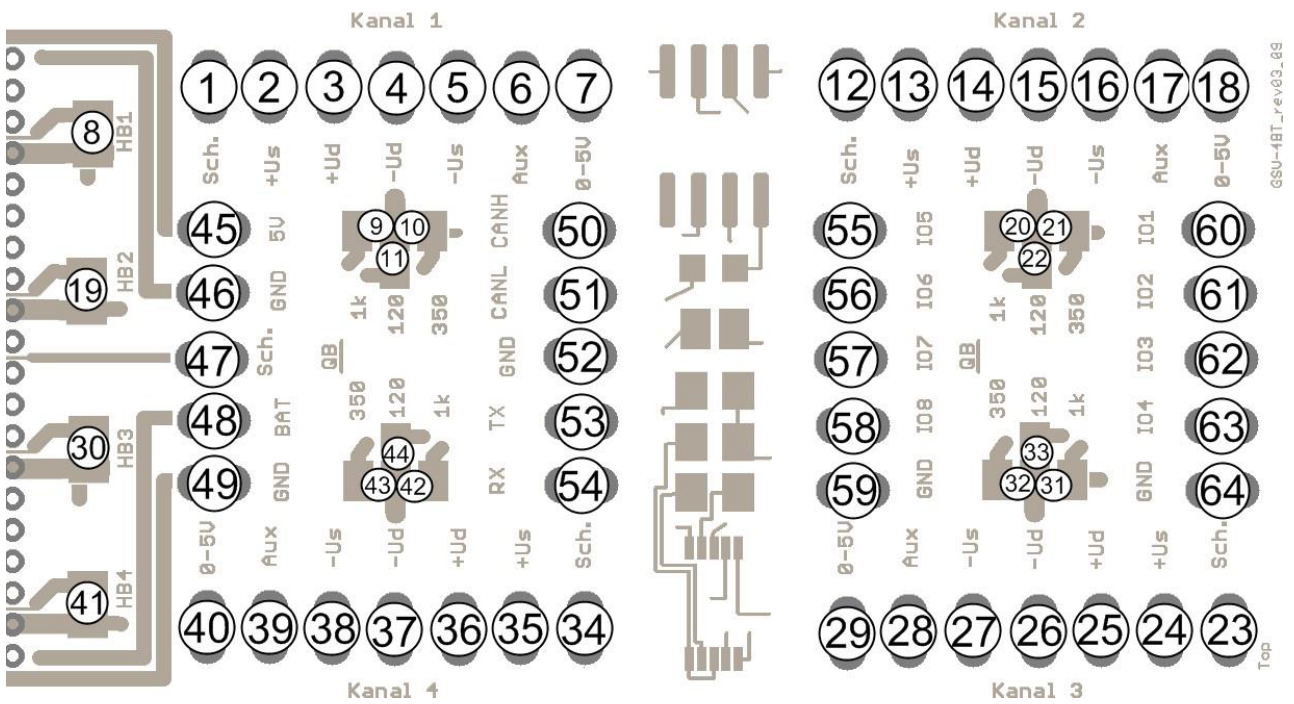

Strain gage full bridge

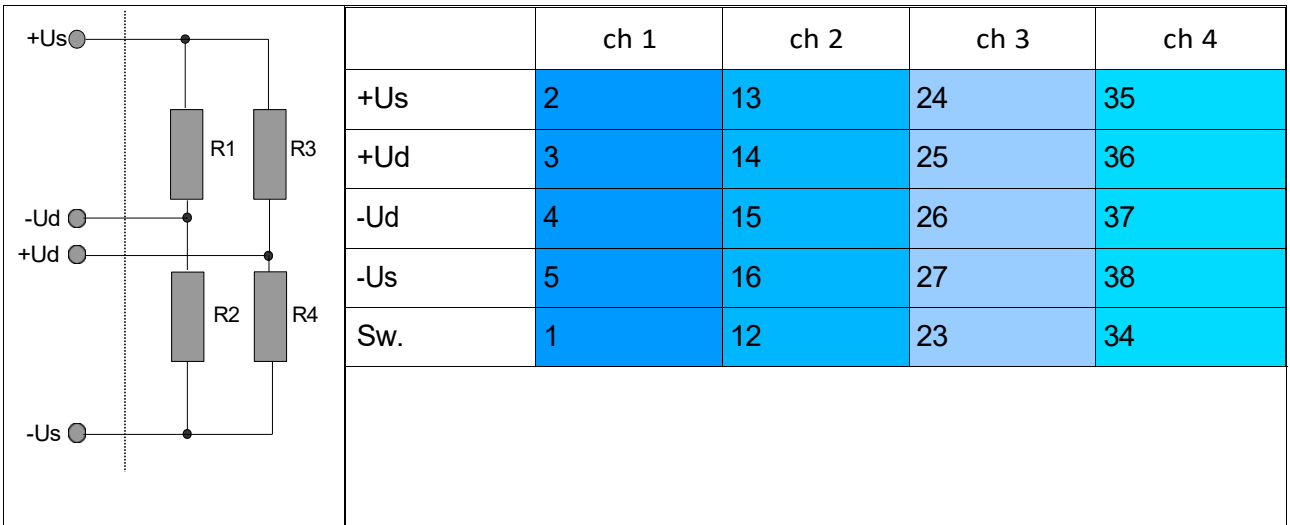

### Strain gage half bridge

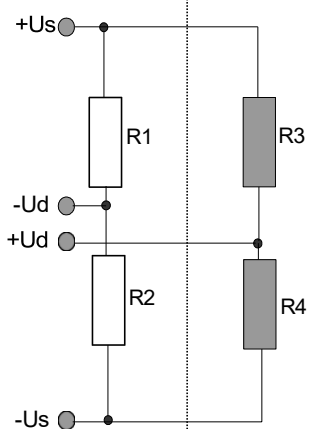

	ch 1	ch 2	ch 3	ch 4
+Us	2	13	24	35
+Ud	3	14	25	36
-Us	5	16	27	38
HBx	8	19	30	41
Sw.	1	12	23	34

The active Strain gage R3 and R4 are connected to the terminals +Us, +Ud and -Us.

HBx: The solder bridges "8", "19", "30" or "41" must be closed so that the internal extension resistors R1 and R2 are activated.

### Strain gage quarter bridge

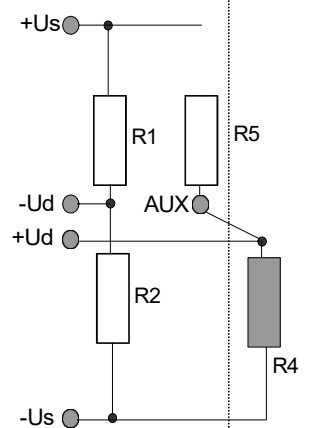

	ch 1	ch 2	ch 3	ch 4
+Ud	3	14	25	36
-Us	5	16	27	38
HBx	8	19	30	41
AUX	6	17	28	39
QB 120	11	22	33	44
QB 350	10	21	32	43
QB 1000	9	20	31	42
Sw.	1	12	23	34

The active Strain gage R4 is connected to the terminals +Ud, AUX and -Us in 3-wire technology.

HBx: The solder bridges "8", "19", "30" or "41" must be closed so that the internal extension resistors R1 and R2 are activated.

A solder bridge should be set depending on the Strain gage resistance (120/350/1000 Ohm), e.g. 120 Ohm at channel 1: Solder bridge 11 (vertical); 350 Ohm at channel 2: Solder bridge 21 (horizontal).

PT-1000

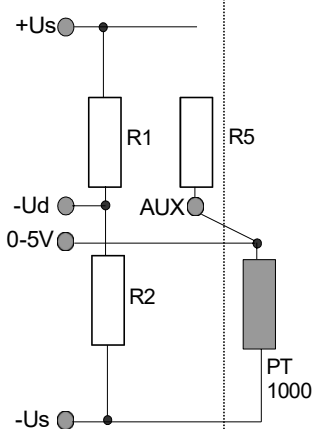

	ch 1	ch 2	ch 3	ch 4
AUX	6	17	28	39
	7	18	29	40
-Us	5	16	27	38
QB 1000	9	20	31	42
HBx	8	19	30	41
Sw.	1	12	23	34

**HBx:** The solder bridges “8”, “19”, “30” or “41” must be closed so that the internal extension resistors R1 and R2 are activated.  
**The solder bridges “9”, “20”, “31” or “42” (horizontal) must be closed.**

Thermocouple cable type K

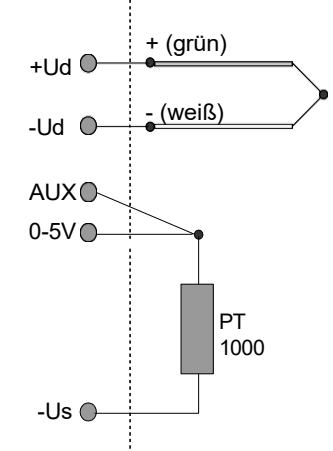

	ch 1	ch 2	ch 3	ch 4
+Ud	3	14	25	36
-Ud	4	15	26	37
-Us	5	-	-	-
QB 1000	9	-	-	-
	7	-	-	-
HBx	8	19	30	41
Sw.	1	12	23	34
AUX	6	17	28	39

**A reference sensor PT1000 must be connected to channel 1, Ue “0-5 V” terminal, AUX and -Us.**  
**The thermocouple cable is connected to terminals +Ud and -Ud.**

Voltage input 0-5 V

		ch 1	ch 2	ch 3	ch 4
	Ue „0-5V“	7	18	29	40
	-Us	5	16	27	38
	Sw.	1	12	23	34

Voltage input 0-10 V

		ch 1	ch 2	ch 3	ch 4
	Ue „0-5V“	7	18	29	40
	-Us	5	16	27	38
	Sw.	1	12	23	34

## Technical data BSC4D-BT M12

Accuracy class	0.05	%
Inputs		
Resolution	16	Bit
Strain gage inputs		
Full bridge	89-5000	Ohm
Half bridge	89-5000	Ohm
Quarter bridge	120, 350, 1000	Ohm
Common mode rejection at 60 Hz common-mode signal	95–110	dB
Measurement frequencies		
Data frequency	0–500	Hz
Sampling frequency	1.92	MHz
Cut-off frequency		
analog	450	Hz
digital	Notch filter, configurable	
Outputs		
Bridge supply voltage	2.5	Volt
Current load capacity	30	mA
Switching outputs/inputs I/O 1-8	TTL level	
Level	5 (active High)	V
Current load capacity:	5	mA
Interface	Bluetooth Standard 2.0+EDR	
Supply voltage		
Nominal range	3.3...4.2	V DC
Current consumption @ 4.2 V DC	< 150	mA
Charge regulator	9,0 ... 36,0	V DC
Current consumption @ 5.2 V DC	< 100	mA
Temperature range		
Nominal temperature range	-10...+65	-10...+65
Storage temperature range	-40...+85	-40...+85
Zero point drift	< 0.05	%/10°C
Sensitivity drift	< 0.01	%/10°C
Dimensions		
L x B x H for BSC4D-BT M12	120 x 80 x 55	mm x mm x mm
Protection type		

for BSC4D-BT M12	IP65	
------------------	------	--

### Switch configuration BSC4D-BT M12

Input	1 brown	2 red	3 orange	4 yellow	5 green	6 blue	7 purple	8 grey
Strain gage	OFF	OFF	OFF	OFF	OFF	ON	ON	OFF
PT1000	ON	OFF	OFF	OFF	OFF	OFF	OFF	ON
Voltage	OFF	OFF	OFF	ON	OFF	OFF	OFF	OFF
Thermo cable + on channel 1 - PT1000	OFF	OFF	OFF	OFF	ON	ON	ON	OFF
Half bridge	ON	OFF	OFF	ON	OFF	OFF	OFF	OFF
Quarter bridge 1000 Ohm	ON	OFF	OFF	OFF	ON	OFF	ON	OFF
Quarter bridge 120 Ohm	OFF	ON	OFF	OFF	ON	OFF	ON	OFF
Quarter bridge 350 Ohm	OFF	OFF	ON	OFF	ON	OFF	ON	OFF
Displacement sensor	OFF	OFF	OFF	ON	OFF	OFF	OFF	OFF

### Pin configuration for external supply voltage M8, 4-pin

The external supply voltage can be connected via 4-pin round plug connector M8.

Pin	Function	Sensor-Aktor Cable M8
1	Supply voltage 9...28 V DC	brown
2	Battery 4,2V	white
3	GND Supply voltage	blue
4	Battery GND	black

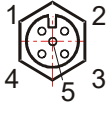

Pin configuration BSC4D-BT M12

Port side	5-pol.	Description	Color
	2	-U <sub>S</sub> negative bridge supply	white
	1	+U <sub>S</sub> positive bridge supply	brown
	3	+U <sub>D</sub> positive differential input	blue
	4	-U <sub>D</sub> negative differential input	black
	5	AUX in input without cable	grey

Connection plan for BSC4D-BT M12

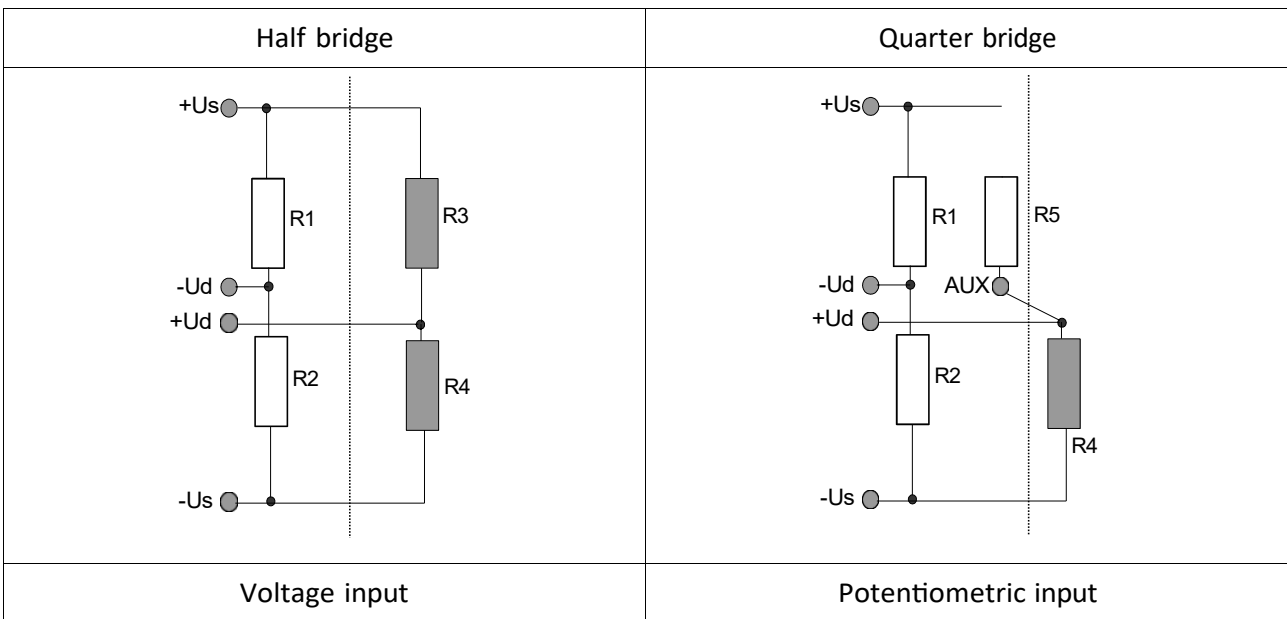

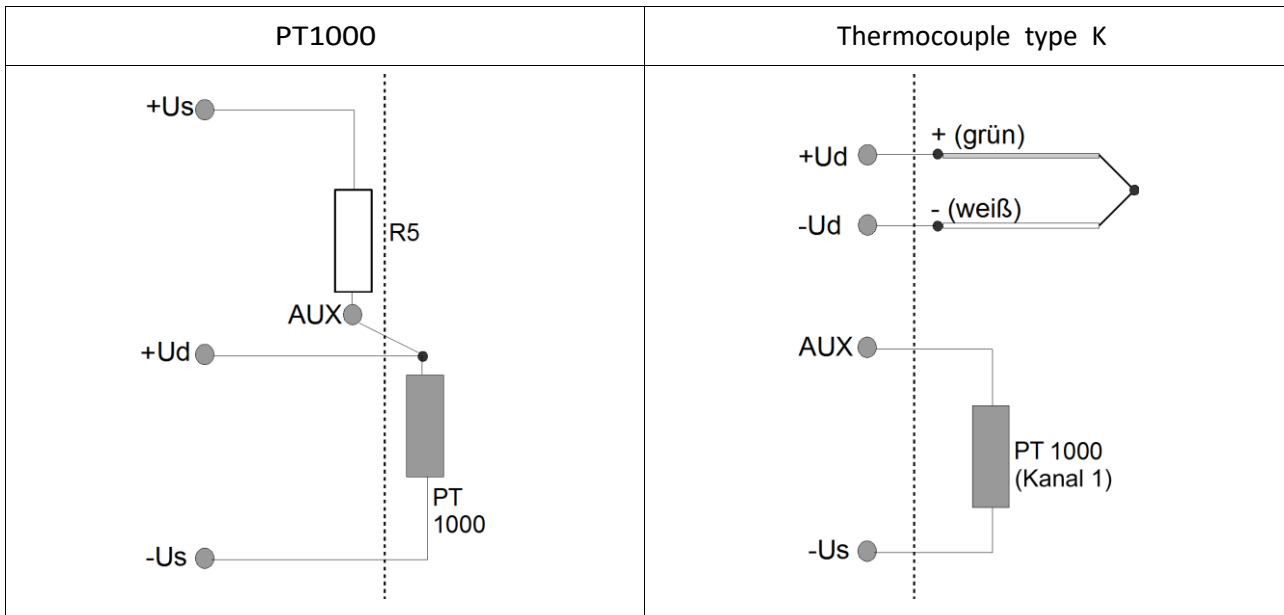
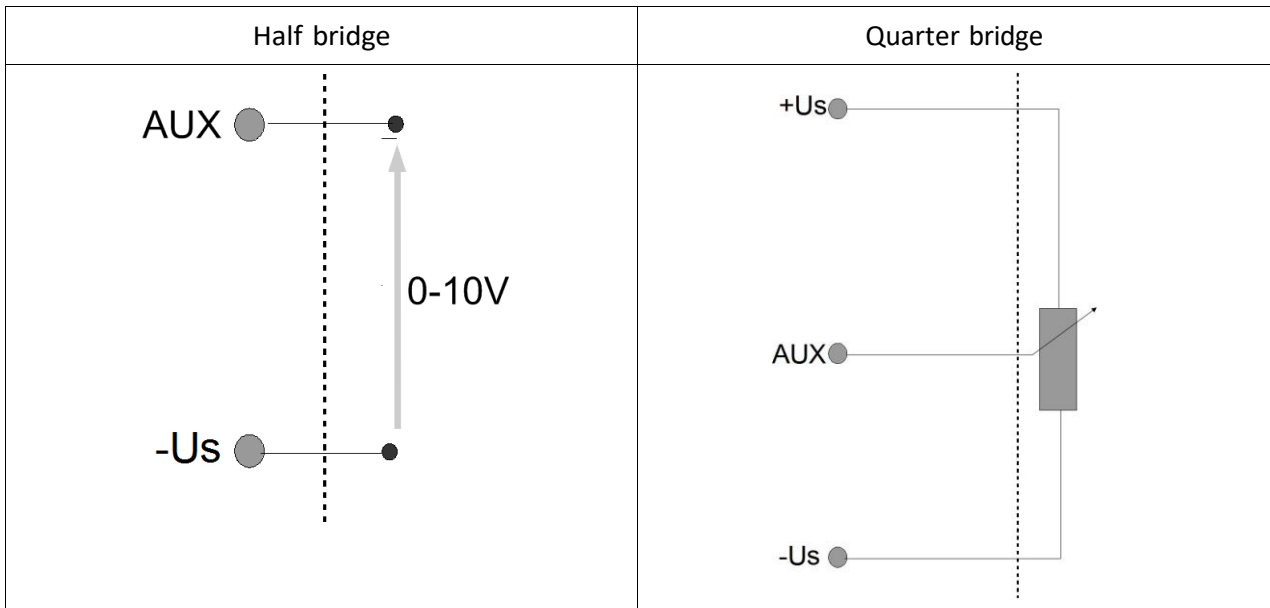

Measurement resolution

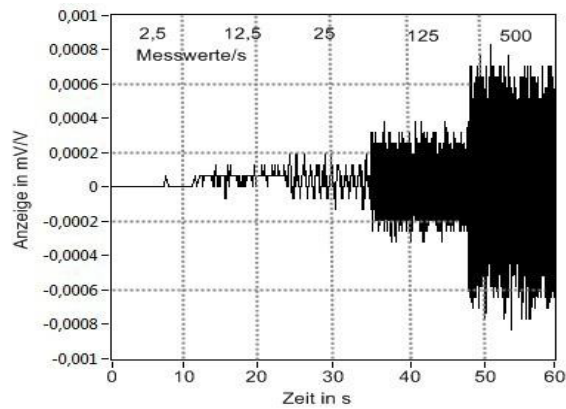

The achievable relation signal / noise depends on the ambient conditions (cable length, shield) and on the settled data rate. The graphic illustrates the resolution with 1m cable, measuring range  $\pm 2\text{mV/V}$  and 350 Ohm Strain gage – Simulator on channel 1.

### Order variants BSC4D-BT

Type	Description
BSC4D-BT	Miniature variant, external battery
Li-Ion 1S/1P/2.6Ah	Li-Ion battery, 2,6Ah, for BSC4D-BT
Adapter-BSC4D-BT	Connecting Adapter with solder connection for BSC4D-BT
Adapter-BSC4D-BT MSTB	Connecting Adapter with screw terminals RM2,5 for BSC4D-BT
Bluetooth-USB-Adapter	Bluetooth receiver with USB Port (to 100m)
BSC4D-BT M12	Variant with housing and plug connector, integrated battery, "Long-Distance" in connection with Bluetooth USB-Dongle UD100
BSC4D-BT LD	Miniature Variant, external battery, „Long Distance“ to 300m in connection with Bluetooth USB-Dongle UD100
Bluetooth USB-Dongle UD100	Bluetooth receiver with USB Port (to 300m, in connection with BSC4D-BT M12 or BSC4D-BT LD

## Programming / configuration

For programming Windows DLL and LabVIEW Vis can be downloaded from the website. Optionally it is possible to program the measuring amplifier directly via serial interface or USB with ASCII Codes.

## Scaling of measured values

Each channel can be configured individually for a defined measuring range, e.g.

for measuring

- with wire strain gages 2 mV/V,
- with wire strain gages 10 mV/V,
- with active sensors 0-5 V,
- with temperature sensors PT1000,
- with type K thermocouples,
- with active sensors 0–10 V,

The measuring range is set using the command “set\_gain”.

105% of the input signal matches a value range of 0x0000 to 0xFFFF.

## Measuring range 2.0 mV/V

Measuring range ±2 mV/V (set_gain 0xB2 <p1> <p2>) with p1=ch, p2=0x01		
Input signal in mV/V	Measuring range in %	16 Bit output value (hexadecimal)
2.1	105.00%	FFFFh
2.0	100.00%	F9E7h
0.0	0.00%	8000h
-2.0	-100.00%	0618h
-2.1	-105.00%	0000h

Conversion of digital output value to analog input signal:

Output value = Highbyte \* 256 + Lowbyte;

Input signal Ud = (output value - 32768) / 32768 \* 2.10 mV/V;

## Measuring range 10.0 mV/V

Measuring range ±10 mV/V (set_gain 0xB2 <p1> <p2>) with p1=ch, p2=0x02		
Input signal in mV/V	Measuring range in %	16 Bit output value (hexadecimal)
10.5	105.00%	FFFFh
10.0	100.00%	F9E7h

Measuring range $\pm 10$ mV/V (set_gain 0xB2 <p1> <p2>) with p1=ch, p2=0x02		
0.0	0.00%	8000h
-10.0	-100.00%	0618h
-10.5	-105.00%	0000h

Conversion of digital output value to analog input signal:

Output value = Highbyte \* 256 + Lowbyte;

Input signal  $U_d = (\text{output value} - 32768) / 32768 * 10.5 \text{ mV/V}$ ;

### Measuring range 0.0 to 5 V

Measuring range 0-5 V (set_gain 0xB2 <p1> <p2>) with p1=ch, p2=0x03		
Input signal in V	Measuring range in %	16 Bit output value (hexadecimal)
5.25	105.00%	FFFFh
5.0	100.00%	F9E7h
0.0	0.00%	8000h

Conversion of digital output value to analog input signal:

Output value = Highbyte \* 256 + Lowbyte;

Input signal  $U_d = (\text{output value} - 32768) / 32768 * 5.25 \text{ V}$ ;

### Measuring range 0.0 to 10 V

Measuring range 0-10 V (set_gain 0xB2 <p1> <p2>) with p1=ch, p2=0x07		
Input signal in V	Measuring range in %	16 Bit output value (hexadecimal)
10.5	105.00%	FFFFh
10	100.00%	F9E7h
0.0	0.00%	8000h

Conversion of digital output value to analog input signal:

Output value = Highbyte \* 256 + Lowbyte;

Input signal  $U_e = (\text{output value} - 32768) / 32768 * 10.5 \text{ V}$ ;

### Measuring range PT1000

Measuring range PT1000 (set_gain 0xB2 <p1> <p2>) with p1=ch, p2=0x04		
Input signal in $^{\circ}\text{C}$	Measuring range in %	16 Bit output value (hexadecimal)
1050	105%	FFFFh
1000	100%	F9E7h
0.0	0.0%	8000h

Measuring range PT1000 (set_gain 0xB2 <p1> <p2>) with p1=ch, p2=0x04		
-40	-4%	6DB0h

Conversion of digital output value to analog input signal:  
 Output value = Highbyte \* 256 + Lowbyte;  
 Input signal Ue = (output value - 32768) / 32768 \* 1050 °C;

### Measuring range K thermocouple cable

Measuring range K-thermocouple cable (set_gain 0xB2 <p1> <p2>) with p1=ch, p2=0x06		
Input signal in °C	Measuring range in %	16 Bit output value (hexadecimal)
1050	105%	FFFFh
1000	100%	F9E7h
0.0	0.0%	8000h
-40	-4%	6DB0h

Conversion of digital output value to analog input signal:  
 Output value = Highbyte \* 256 + Lowbyte;  
 Input signal Ud = (output value - 32768) / 32768 \* 1050 °C;

### Commands for configuration

The code of the command concerned is sent to the measuring amplifier for configuration. Some commands expect parameters, e.g. the channel number “ch” and potentially other bytes.

**Note:** To set the configuration, the data transfer should be interrupted by sending the command “stop\_transmission”.

After completing the configuration, the data transfer can be restarted again by executing the command “start\_transmission”.

**Notes:** After each switch-on, the “normal mode” must be set in order to send commands (0x26 01 62 65 72 6C 69 6E).

### List of commands

The table lists the available commands (rev0x0B) and their hexadecimal codes.

Commands	Code	p1	p2	p3	p4	p5	p6	p7	p8	p9
set_zero	0C	ch								
save_konfiguration	09	B								
restore_konfiguration	0A	B								

Commands	Code	p1	p2	p3	p4	p5	p6	p7	p8	p9
set_offset	0B	ch	B	HB	B	LB				
get_offset	0D	ch	B							
set_frequency	12	B								
get_frequency	16									
get_serial_number	1F									
set_serial_number	1E	B	B	B	B	B	B	B	B	
set_threshold	20	B	HB	LB						
get_threshold	21	B								
stop_transmission	23									
start_transmission	24									
set_mode	26	B	B	B	B	B	B	B		
get_mode	27									
set_tx_status	28	B								
get_tx_status	29									
get_firmware_version	2B									
set_power_on	2C	B								
get_power_on	2D									
set_threshold_mode	2E	ch	B							
get_threshold_mode	2F									
get_value	3B									
set_cal_factor	88	ch	B	HB	B	LB				
get_cal_factor	89	ch	B							
set_rs232	B0	B								
get_rs232	B1									
set_gain	B2	ch	B							
get_gain	B3									
set_unit	B4	ch	B							
get_unit	B5	ch								
set_digital	B6	B	B							

Commands	Code	p1	p2	p3	p4	p5	p6	p7	p8	p9
get_digital	B7	B								
set_digital_on_off	B8	B	B							
get_digital_port	B9									
set_user_scale	BA	ch	HB	B	B	LB				
get_user_scale	BB	ch	HB	B	B	LB				
set_user_sring	BC	HB	B	B	B	LB				
get_user_sring	BD									
reserviert	BE									
get_digital_port A	BF									
set_can_bitrate	C0	B								
get_can_bitrate	C1									
reserviert	C2									
reserviert	C3									
set_can_id	C5	B	HB	B	B	LB				
get_can_id	C6	B								
reserviert	C7	ch								
reserviert	C8	ch								
reserviert	D0	B	B	B	B	B	B	B		
reserviert	D1	ch								
reserviert	D2	B	B							
reserviert	D3									
reserviert	D4									
reserviert	D5	B	B							
reserviert	D6									

Table 4: Command list for BSC4D (ch = channel number), B = byte, HB = high byte, LB = low byte) Commands in grey are reserved for the initial setup or calibration. The commands shaded grey are only available after restarting.



## Description of commands

### set\_gain (B2)

With the command set\_gain, the 4 inputs on the measuring amplifier can be configured individually for various sensor types.

Parameters in HEX	Description
01	Strain gage input $\pm 2$ mV/V
02	Strain gage input $\pm 10$ mV/V
03	analog input 0-5 V
04	Input for PT1000 -40°C ... 1000 °C
06	Input for K-thermocouple cable -40°C ... 1000 °C
07	analog input 0 – 10 V

### set\_frequency (12)

The data frequency is set with the command set\_frequency. The measurement data is acquired with the data frequency and are ready to be transmitted via the interface (CANBus, RS232, Bluetooth, GPRS, etc.) By setting the data frequency, the digital filter is set automatically, see data frequencies and filter properties.

After executing the command “start\_transmission”, the measurement data is transmitted steadily at the set data frequency. After executing the command “stop\_transmission”, the measuring data is only sent when required. It can be requested with the command “get\_value” or for devices with CAN bus via CAN-Sync\_ID (page 53).

**Note:** Care should be taken to ensure that the request for measured values does not occur more frequently than the set data frequency. Otherwise, a current measured value will not be available every time there is a request. The same measured values are requested repeatedly.

Parameters in HEX	Data frequency in Hz( nominal)	Data frequency in Hz( effective)
A0	0,63	0,625
A1	1,25	1,250

Parameters in HEX	Data frequency in Hz( nominal)	Data frequency in Hz( effective)
A2	2,5	2,500
A3	3,75	3,750
A4	6,25	6,250
A5	7,5	7,500
A6	12,5	12,400
A7	15	14,7
A8	25	24,4
A9	125	125
AA	250	250
AB	500	500
AC	937,5	...

set\_can\_bitrate (C0) / get\_can\_bitrate (C1)

Parameters in HEX	Bitrate in kbit/s
10	20
20	50
30	80
40	100
50	125
60	250
70	500 (standard)
80	1000

Parameters in HEX	Bitrate in kbit/s

save\_configuration (0A) / restore\_configuration (09)

The entire configuration (data frequency, configuration of inputs, etc.) can be saved and restored as a parameter set. Two memories are available for the configuration.

Parameters in HEX	Description
01	Manufacturer setting
02	User setting 1
03	User setting 2

set\_user\_scale (BA) / get\_user\_scale (BB)

A scaling factor in 32 Bit format can be stored for each channel. This scaling factor is stored in the EEPROM of the measuring amplifier and can be read with get\_user\_scale.

Parameters in HEX	Memory No.	Label
01	1	Channel 1
02	2	Channel 2
03	3	Channel 3
04	4	Channel 4

Number format:

Sign	Index	Significand
Bit 0	Bit 1 ... Bit 8	Bit 9 ... Bit 31

### Protocol for measured values

Measured values are framed by a prefix 0xA5 and a postfix from the sign 0x0D 0x0A (carriage return linefeed).

The entire frame is 11 bytes long.

Prefix	Channel 1		Channel 2		Channel 3		Channel 4		Postfix	
A5	HB	LB	HB	LB	HB	LB	HB	LB	0D	0A

Table 5: Protocol for transmitting the measured values via RS232 interface

### Protocol for commands

After switching on, only the commands:

- get\_value (0x3B)
- set\_mode (0x26 01 62 65 72 6C 69 6E)
- get\_mode (0x27)
- get\_tx\_status (0x29)
- get\_firmware\_version (0x2B)

can be used! To be able to use all of the commands, “set\_mode” has to be sent.

Commands begin with the code followed by parameters.

Code	Parameter			
xx	p1	p2	...	pn

Examples:

Requesting serial number **1F**

Setting channel 1 to zero: **0C 01**

### Protocol for responding to commands

Responses are framed by a prefix 0x3B and a postfix from the sign 0x0D 0x0A (carriage return linefeed).

The entire frame has a variable length. The number of frames still to follow is given with “n”.

The number of variable bytes is defined in the fourth and fifth Byte with the data word “len”.

The entire length of the response is (10 + len) bytes.

The command “get\_value” is an exception. The response to this command takes place with a protocol for measured values.

Prefix	Code	n	len		No.			len bytes				Postfix	
3B	xx	B	HB	LB	aa	bb	cc	p1	p2	...	pn	0D	0A

Table 6: Protocol for responding to commands

Example: Releasing commands

Send: 0x26 01 62 65 72 6C 69 6E

Example: Locking commands

Send: 0x26 00 62 65 72 6C 69 6E

Example: Request serial number

Send: 0x23

Send: 0x1F

Receive 0x 3B 1F 0100 08 30 35 30 30 38 34 34 39 30 35 30 0D 0A

Send 0x24

Result: The serial number is "08449050".

Example: Change status(Send measured value OFF/ON)

To permanently save the value send stop or start measured value, the command set\_tx\_status (0x28<p1>) can be used.

Parameters in HEX	Parameters in Bit	Current	After switching on
00	0 0 0 0 0 0 0 0	Send measured value OFF	Send measured value OFF
01	0 0 0 0 0 0 0 1	Send measured value OFF	Send measured value ON
02	0 0 0 0 0 0 1 0	Send measured value ON	Send measured value OFF
03	0 0 0 0 0 0 1 1	Send measured value ON	Send measured value ON

Send: 0x23

Send: 0x29

Receive : 0x 3B 29 0100 01 30 33 33 01 0D 0A

Result: Current-OFF , After switching on-ON

Send: 0x28 02

Send: 0x29

Receive : 0x 3B 29 0100 01 30 33 33 02 0D 0A

Result: Current-ON , After switching on-OFF

### Digital IOs

The entire port is always read (IO8 to IO1).

BSC4D CAN assignment:

Digital IO	BSC4D-CAN	BSC4D-BT	Port
01	Digital 1	IO1	IO1
02	-	IO2	IO2
03	Digital 2	IO3	IO3
04		IO4	IO4
05	Digital 3	IO5	IO5

Digital IO	BSC4D-CAN	BSC4D-BT	Port
06		IO6	IO6
07	Digital 4	IO7	IO7
08	Digital 5	IO8	IO8

Example: Read port

Send: 0x23

Send: 0xB9

Receive : 0x 3B B9 0100 01 30 33 33 00 0D 0A

Result: all inputs and outputs are "low"

Parameters in HEX	Parameters in Bit	Port
00	0 0 0 0 0 0 0 0	IO8 IO7 IO6 IO5 IO4 IO3 IO2 IO1

The digital port can be configured with set\_digital (0xB6 <p1><p2>) and set\_digital\_on\_off(0xB8 <p1> <p2>). The port is set with <p1>/

set\_digital (0xB6 <p1> <p2>)

Parameters in HEX <p2>	Description
00	Eingang
01	Ausgang
02	get_Value
0A	Tara all
0B	Tara Kanal1
0C	Tara Kanal2
0D	Tara Kanal3
0E	Tara Kanal4
0F	Slave
10	Master

Parameters in HEX <p2>	Description
11	SW1
12	SW2
13	SW3
14	SW4
15	SW5
16	SW6
17	SW7
18	SW8
21	SW1 rel.
...	...
28	SW8 rel.
31	SW1 1s
...	...
38	SW8 1s
41	SW1 rel. 1s
...	...
48	SW8 rel. 1s
51	SW1 inv.
...	...
58	SW8 inv.
61	SW1 inv. rel.
...	...
68	SW8 inv. rel.

Parameters in HEX <p2>	Description
71	SW1 inv. 1s
...	...
78	SW8 inv. 1s
...	...
81	SW1 inv. rel. 1s
...	...
88	SW8 inv. rel. 1s

set\_digital\_on\_off(0xB8 <p1> <p2>)

Parameters in HEX <p2>	Parameters in Bit	Port	Description
00	0 0 0 0 0 0 0 0	For IO1 to IO8	OFF
01	0 0 0 0 0 0 0 1	For IO1 to IO8	ON

Example: Change IO1

Send: 0x23

Send: 0xB6 01 0B

Send: 0xB7

Receive : 0x 3B B7 0100 02 30 33 33 01 0B 0D 0A

Result: IO1 is configured as Tara for channel1

Send: 0xB6 01 00

Send: 0xB7

Receive : 0x 3B B7 0100 02 30 33 33 01 00 0D 0A

Send: 0x24

Result: IO1 is configured as an input and can be read with 0xB9

set\_threshold (0x20 <p1> <p2>)

Parameters in HEX <p1>	Description	Channel assignment	Switching threshold
01	SW1	1	ON



Parameters in HEX <p1>	Description	Channel assignment	Switching threshold
02	SW1	1	OFF
03	SW2	1	ON
04	SW2	1	OFF
05	SW3	2	ON
06	SW3	2	OFF
07	SW4	2	ON
08	SW4	2	OFF
09	SW5	3	ON
0A	SW5	3	OFF
0B	SW6	3	ON
0C	SW6	3	OFF
0D	SW7	4	ON
0E	SW7	4	OFF
0F	SW8	4	ON
10	SW8	4	OFF

By setting the on and off switching thresholds differently, a hysteresis can be programmed. The second parameter (<p2>) is the switching threshold in HEX e.g.: 0x89 FF.

**Caution:** in order to compare the threshold value with the measured value directly, it has to be added with 0x80 00.

Example: Configuration of SW1 IO8 ( or digital 5)

Send: 0x 23

Send: 0x B6 08 11

Configure IO8 for SW1

Send: 0x 20 01 01 00

The turn-on threshold of SW1 is set to 0x81 00.

Send: 0x 20 02 FE 00

The turn-off threshold of SW1 is set to 0x7E 00.

If the measured value increases above 0x81 00, IO8 is switched on. If the measured value falls below 0x7E 00, IO8 is switched off.

analog input

Example: Requesting the configuration of analog inputs

Send: 0x23

Send: 0xB3

Receive : 0x 3B B3 0100 04 30 35 30 01 01 02 03 0D 0A

Send 0x24

Result: Channel 1 = 2 mV/V, channel 2 = 2 mV/V, channel 3 = 10 mV/V, channel 4 = 0-5 V;

Example: Setting the configuration of analog inputs

Specification: configuring channel 1 to channel 4 for PT1000

Send: 0x23

Send: 0xB2 01 04

Send: 0xB2 02 04

Send: 0xB2 03 04

Send: 0xB2 04 04

Send 0x24

Example: Setting the data frequency to 12.5 Hz

Specification: The measured value should be sent steadily with a frequency of approx. 12.5/s.

Send: 0x23

Send: 0xA6

Send 0x24

## CAN bus

Devices with CAN bus have the same command structure as devices with serial interfaces or Bluetooth or GPRS. Prefixes and postfixes are omitted if the measured values and responses are sent within a CAN bus frame.

### Protocol for measured values

Measured values via CAN are always transmitted in a CANbus frame. Bytes 1 to 8 include the measurement data of the 4 channels with 16 bit each. First the highbyte (HB) and then the lowbyte (LB) is sent.

Channel 1		Channel 2		Channel 3		Channel 4	
HB	LB	HB	LB	HB	LB	HB	LB

Table 11: CAN frame with measurement data;

### Protocol for commands

Commands begin with the code followed by parameters.

Code	Parameter			
xx	p1	p2	...	pn

Examples:

Requesting serial number **1F**

Setting channel 1 to zero: **0C 01**

### Protocol for responding to commands

Commands for the measuring amplifier are transmitted in the CAN frame (data range). If the measuring amplifier sends a response, a command response frame is sent.

Head frame:

Prefix	Code	n	len		No.		
3B	xx	B	HB	LB	aa	bb	cc

Table 12: Head frame for responding to commands via CAN bus

Frame 1 ... n

B	B	B	B	B	B	B	B
B	B	B	B	B	B	B	B

B	B	B	B	B	B	B	B
---	---	---	---	---	---	---	---

Table 13: Following frame for responding to commands via CAN bus

Example: Request serial number

Send: 0x23  
 Send: 0x1F  
 Receive 0x 3B 1F 01 00 08 30 35 30  
 0x 30 38 34 34 39 30 35 30  
 Send 0x24  
 Result: The serial number is "08449050".

Example: Requesting the configuration of analog inputs

Send: 0x23  
 Send: 0xB3  
 Receive 0x 3B B3 01 00 04 30 35 30  
 0x 01 01 02 03  
 Send 0x24  
 Result: Channel 1 = 2 mV/V, channel 2 = 2 mV/V, channel 3 = 10 mV/V, channel 4 = 0-5 V;

Example: Setting the configuration of analog inputs

Specification: Configuring channel 1 to channel 4 for 0 - 5V

Send: 0x23  
 Send: 0xB2 01 03  
 Send: 0xB2 02 03  
 Send: 0xB2 03 03  
 Send: 0xB2 04 03  
 Send 0x24

Configuring the CAN-ID

set\_id(0xC5 <p1> <p2>)

CAN-ID for receiving measurement data <p1>=0x01

The default value of CAN-ID for receiving measurement data is 0x00 00 06 10 (<p2>).

CAN-ID for receiving responses <p1>=0x02

The default value of CAN-ID for receiving responses is 0x00 00 06 11 (<p2>).

CAN-ID for sending commands <p1>=0x06

The default value of CAN-ID for sending commands is 0x00 00 01 11 (<p2>).

CAN-ID for synchronising the measurement data <p1>=0x05

To request measured values, the same CAN-ID is available for all measuring amplifiers (CAN-Sync-ID). All frames with this CAN-Sync-ID trigger the sending of a measured value. The default value of CAN-Sync-ID for sending is 0x00 00 01 10 (<p2>).

**Note: The CAN-ID is changed immediately (this should be noted particularly for the ID for sending commands and the CAN baud rate.)**

Example: Configuring the CAN-Bitrate

Send: 0x 23  
Send: 0x C0 60

Converting the baud rate to 250 kBit on the CAN bus (or CAN adapter)

Send: 0x C1  
Receive 0x 3B C1 01 00 01 30 35 30  
0x 60  
Send 0x 24

Example: Configuring the CAN-ID

Send: 0x 23  
Send: 0x C6 06  
Receive 0x 3B C6 01 00 05 30 35 30  
0x 06 00 00 01 11

The CAN-ID for receiving commands is set to 0x00 00 01 11.

Send: 0x C5 06 00 00 01 00

Converting the ID to 0x00 00 01 00 for sending commands in the program.

Send: 0x C6 06  
Receive 0x 3B C6 01 00 05 30 35 30  
0x 06 00 00 01 00  
Send 0x 24

The CAN-ID for receiving commands is set to 0x00 00 01 00.

## Data frequency and filter

### analog filter

The integrated analog filter is a first-order low-pass filter with a cut-off frequency of 1 kHz. It is set as an *antialiasing* filter for the A-D converter. This filter is permanently installed and cannot be changed.

### Digital filter

The digital filter is indirectly set with the data frequency. The effective data frequency may differ slightly from the set (nominal) data frequency. The grey shaded settings are recommended as with these settings faults with a mains frequency of 50 Hz are best suppressed by the integrated “notch filter”.

Data frequency in Hz (nominal)	Data frequency in Hz (effective)	Notch frequency in Hz	-3db cut-off frequency in Hz (digital filter)	Parameters for “set frequency”
500	500	7500	3003	0xAB
250	250	2000	878	0xAA
125	125	1000	441	0xA9
25	24,4	100	44.2	0xA8
15	14,7	60	26.5	0xA7
12,5	12,4	50	22.1	0xA6
7,5	7,5	30	13.3	0xA5
6,25	6,25	25	11.1	0xA4
3,75	3,75	15	6.63	0xA3
2,5	2,5	10	4.42	0xA2
1,25	1,25	5	2.21	0xA1
0,625	0,625	2.5	1.1	0xA0

Table 10: data frequencies and filter properties

50 Hz Notch Filter
60 Hz Notch Filter

Annex

Connection figures for BSC4D-BT SD and BSC4D-BT LD

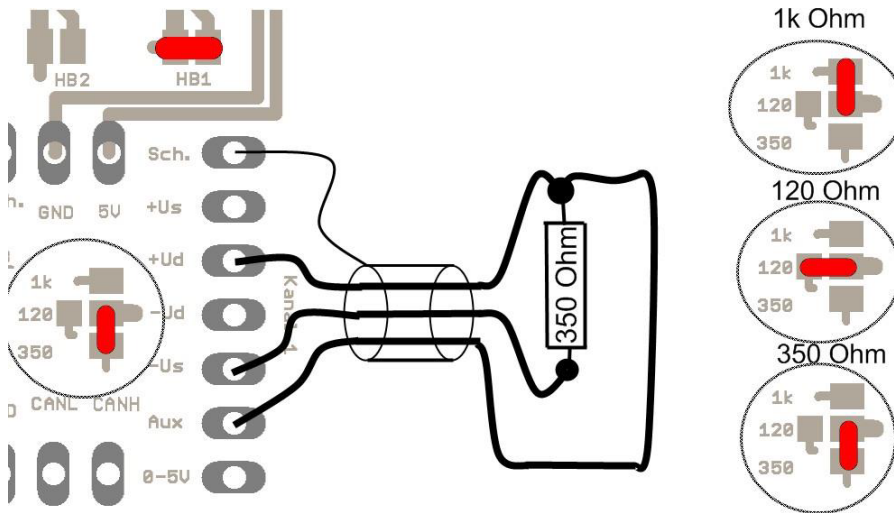

Figure 6: Strain gage-Quarter bridge

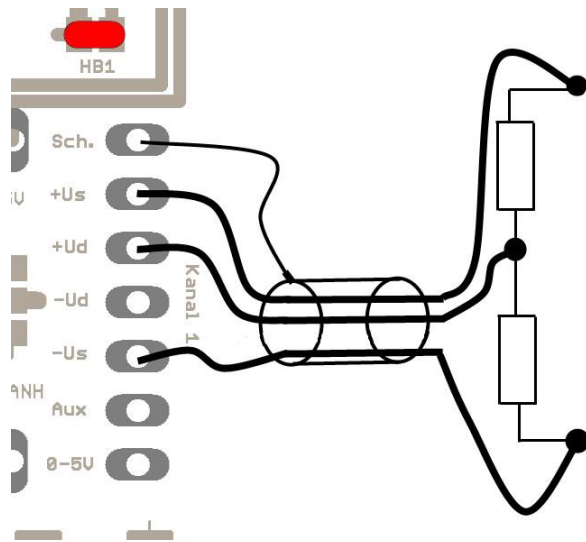

Figure 7: Strain gage-Half bridge

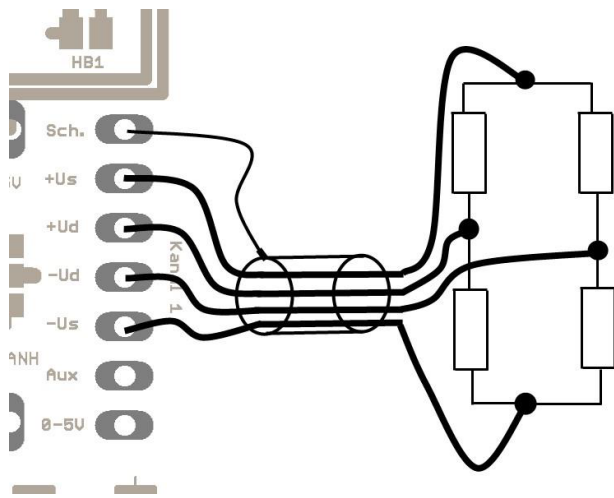

Figure 8: Strain gage-Full bridge

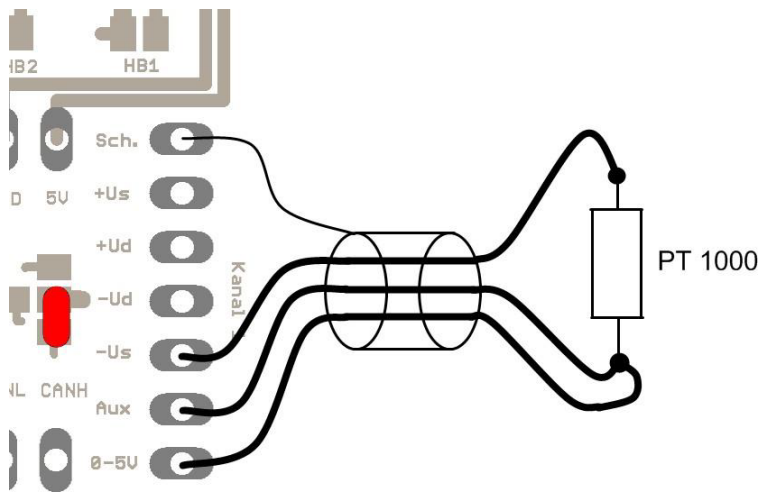

Figure 9: PT1000



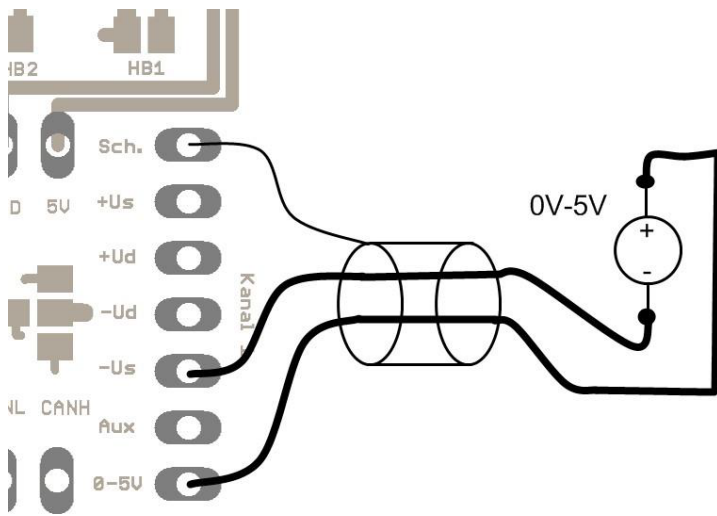

Figure 10: Voltage

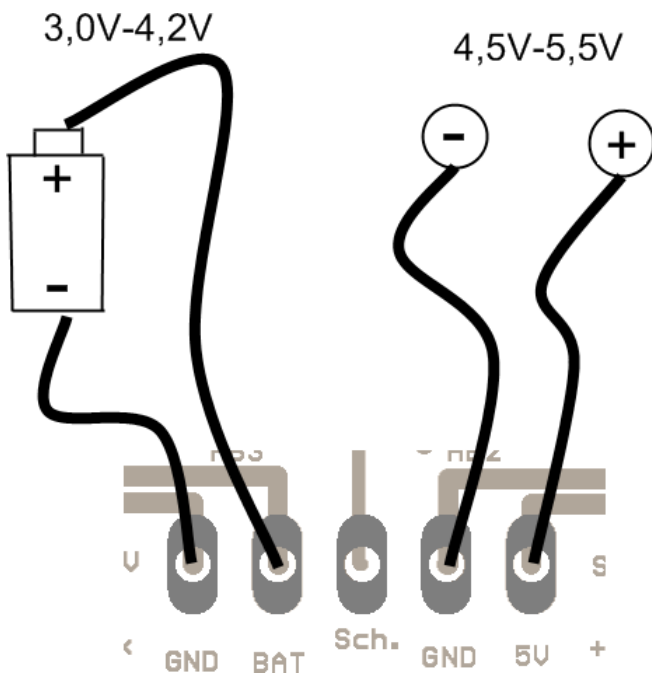

Figure 11: Connection battery, optionally connection load 5V

## Warranty

All instrument products from Interface Inc., ('Interface') are warranted against defective material and workmanship for a period of (1) one year from the date of dispatch. If the 'Interface' product you purchase appears to have a defect in material or workmanship or fails during normal use within the period, please contact your Distributor, who will assist you in resolving the problem. If it is necessary to return the product to 'Interface' please include a note stating name, company, address, phone number and a detailed description of the problem. Also, please indicate if it is a warranty repair. The sender is responsible for shipping charges, freight insurance and proper packaging to prevent breakage in transit. 'Interface' warranty does not apply to defects resulting from action of the buyer such as mishandling, improper interfacing, operation outside of design limits, improper repair or unauthorized modification. No other warranties are expressed or implied. 'Interface' specifically disclaims any implied warranties of merchantability or fitness for a specific purpose. The remedies outlined above are the buyer's only remedies. 'Interface' will not be liable for direct, indirect, special, incidental, or consequential damages whether based on the contract, tort or other legal theory. Any corrective maintenance required after the warranty period should be performed by 'Interface' approved personnel only.