

Interface

FORCE MEASUREMENT SOLUTIONS.

Strain Gage Transducer Indicator

Model: 9820

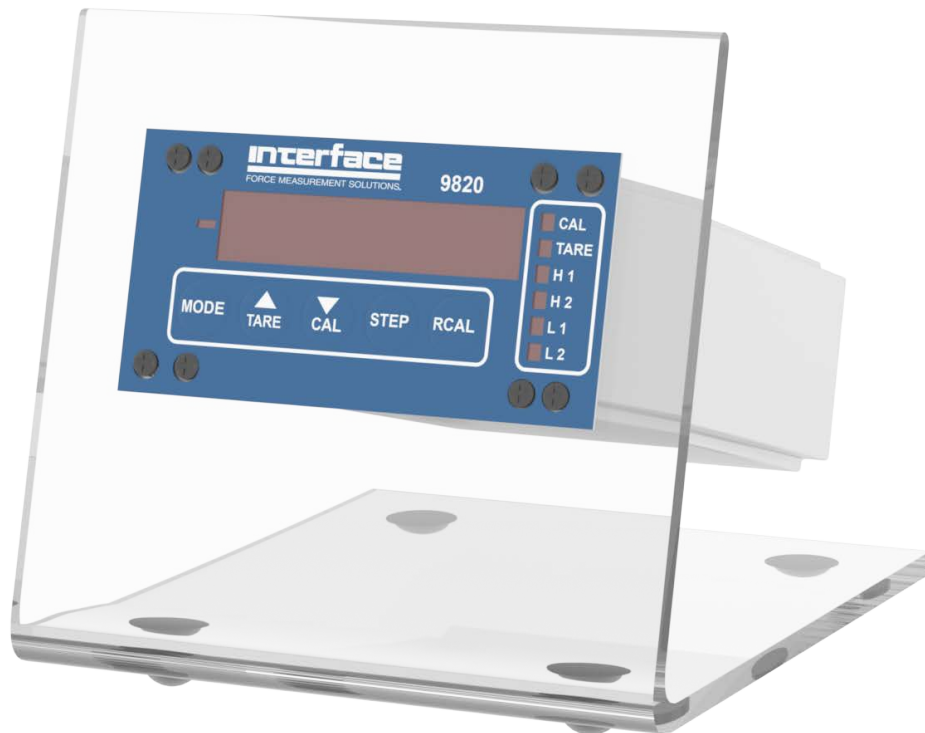

9820 Installation & User Manual

TABLE OF CONTENTS

DESCRIPTION and SPECIFICATIONS	1
INSTALLATION and WIRING	2
SWITCH and FUNCTION DEFINITIONS	6
OPERATING INSTRUCTIONS	10
CALIBRATION INSTRUCTIONS	13
PROGRAM MENU DIAGRAM	17
WARRANTY.....	18

FIGURES

Figure 1 Model 9820 Front Panel View	3
Figure 2 Model 9820 Rear Panel View	3
Figure 3 Transducer Wiring	4
Figure 4 Location of Jumpers and Adjustment Potentiometers	4
Figure 5 Location of RCAL Jumper	5



DESCRIPTION

The Model 9820 is a microprocessor-based digital indicator capable of interfacing directly to a low level strain gage load cell transducer. An internal, high gain, fully-differential amplifier and a 4 1/2 digit analog-to-digital converter combine to accurately digitize the input signal. A 5V @ 60mA or 10V @ 120mA, short circuit protected, transducer excitation supply is also provided. A +/-10VDC analog output signal, with a 2kHz bandwidth, comes standard with the instrument. A front panel RCAL switch provides a convenient calibration feature. TARE and CALIBRATION are easily performed via front panel pushbuttons.

SPECIFICATIONS

Excitation voltage: Jumper selectable 5 or 10 (Default) VDC
Excitation current: 60mA @ 5VDC, 120mA @ 10VDC
Input amp gain: Jumper selectable, 40 or 80
Signal input range: +/-25mV at Input amp gain = 80
 +/-50mV at Input amp gain = 40 (Default)
Max internal counts: +/- 19,999 over signal input range
Max display range: +/- 99,999
Sensitivity: 1.25uV/internal count at input amp gain = 80
Conversion rate: 2.5 samples/second
Filter: 2-pole, 10Hz low pass
Nonlinearity: +/- 0.01% +/- 1 internal count
Step Response: 500ms
CMRR: 120dB @ 50-60Hz
Input impedance: 1000 megohm (min)
Input bias current: 10nA (max)
Zero tempco: 1uV/degC (typ)
Gain tempco: 20ppm/degC (typ)
Operating range: -10 to 50 degC
Input Power: 115 or 230 VAC (solder pad jumper selectable)
Pkg dimensions: 3.78W x 1.89H x 5.13D

INSTALLATION AND WIRING

INSTALLATION

The Model 9820 enclosure is designated for panel mounting in a 1/8 DIN cutout. The cutout dimensions are shown below.

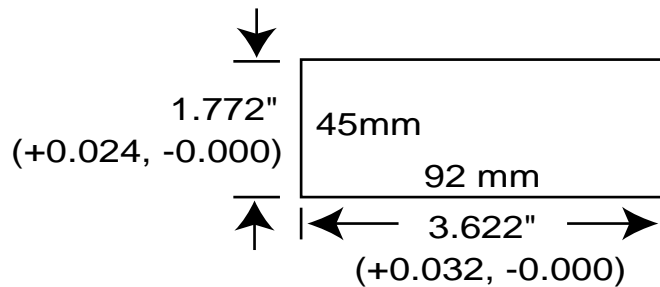

To panel mount the 9820, perform the following steps.

1. Rotate the four pawl screws (outside screws in each corner) several turns counter-clockwise to retract the pawls. Make sure the pawls retract enough to clear the back of the mounting panel. The pawls may be retracted to accomodate panel thicknesses up to 0.25 inches (6.35mm).
2. Insert the instrument into the panel cutout.
3. Position the pawls so that their elongated dimension overlaps the panel cutout, then tighten the screws. Do not over-tighten.
4. Installation complete.

WIRING

Reference Figure 3 for TRANSDUCER wiring information. Power is applied with a 3-prong AC power cord. The instrument is protected by a 250V, 250mA fast acting 5mm fuse. The fuse holder is an integral part of the input power connector. A spare fuse is provided in the fuse holder. Internal solder jumpers are provided to allow 115V AC or 230VAC operation (Reference Figure 6 on page 5).

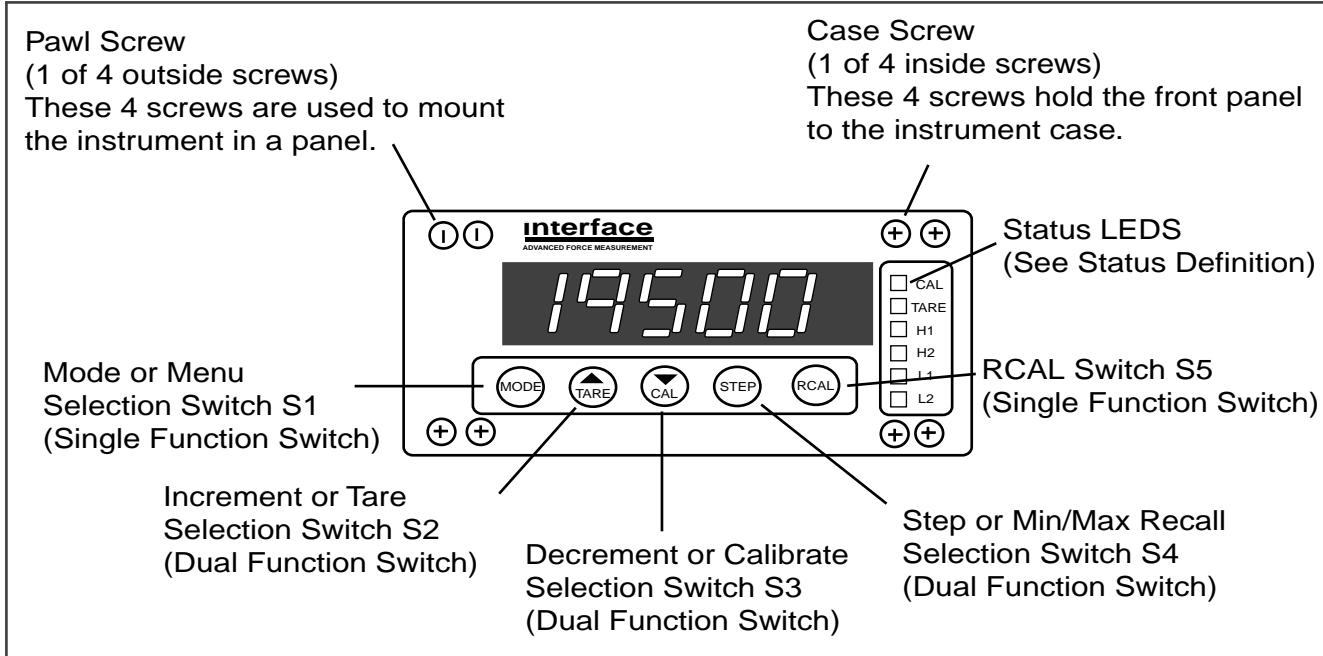

Figure 1. Model 9820 Front Panel View

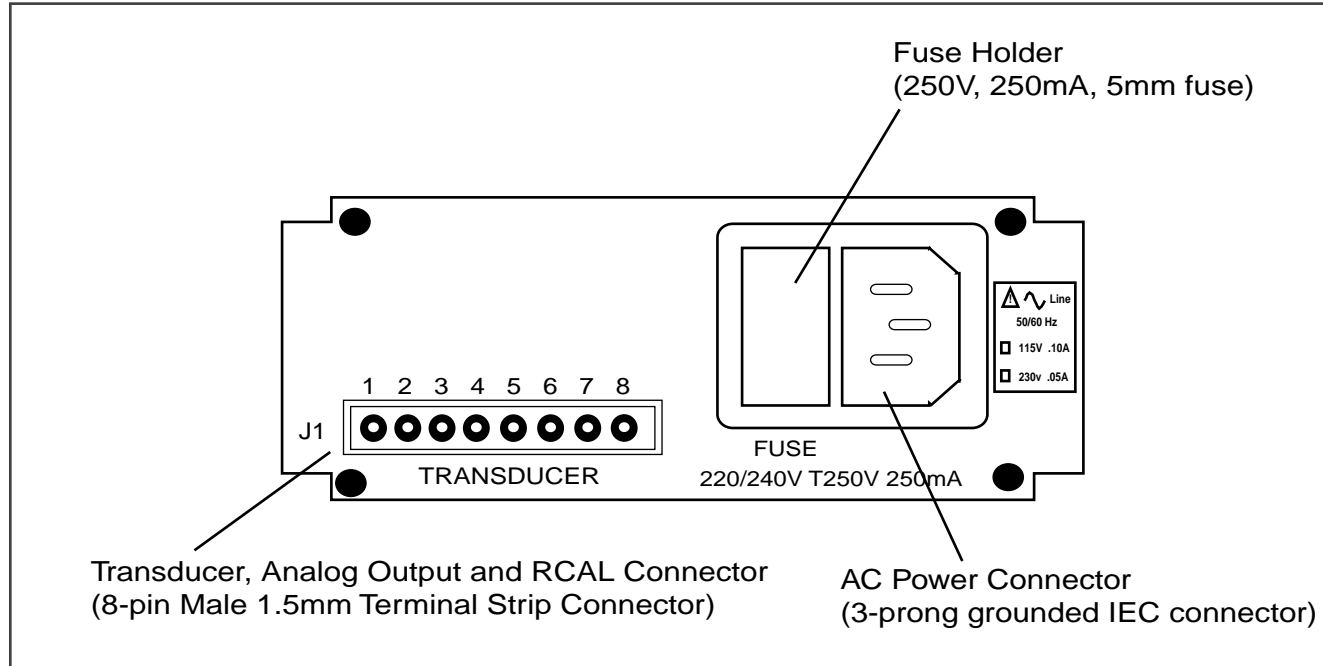

Figure 2. Model 9820 Rear Panel View

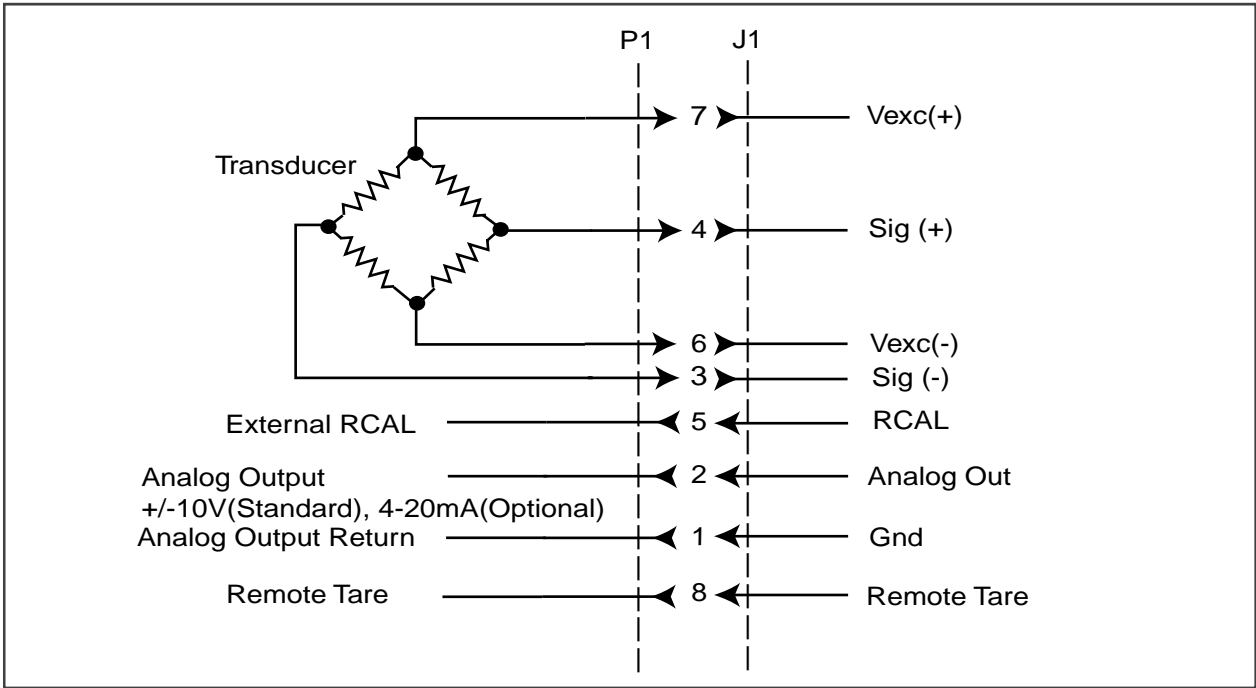

Figure 3. Transducer Wiring

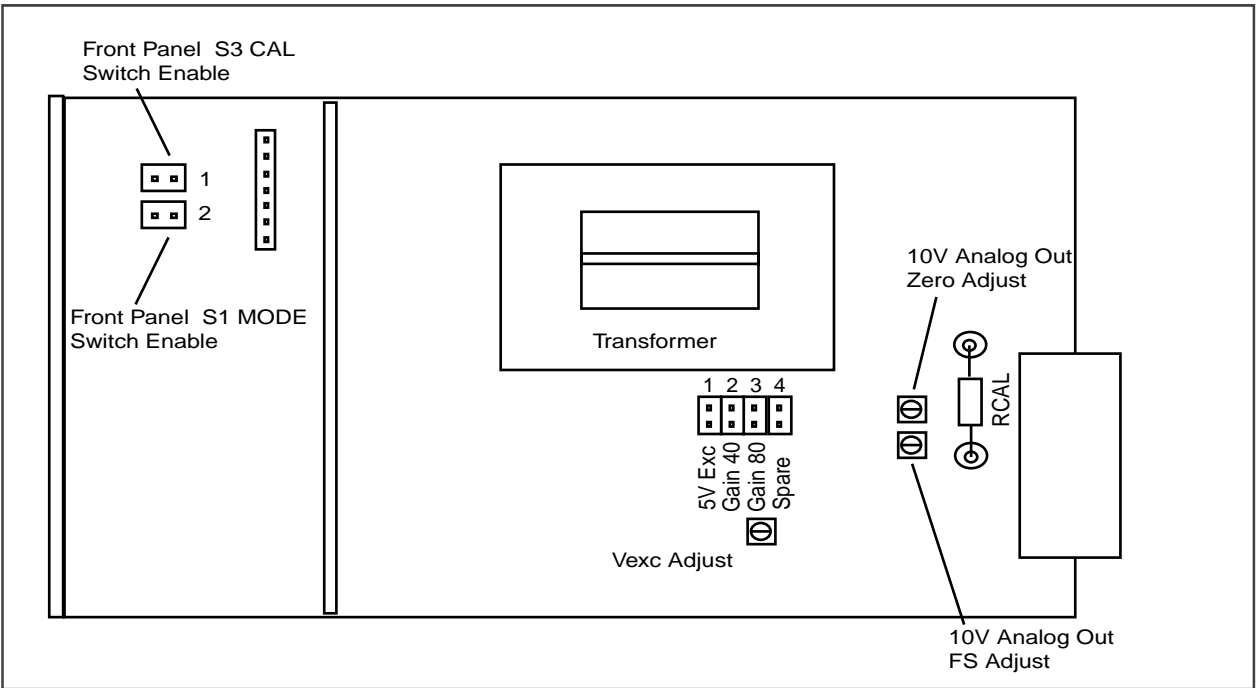

Figure 4. Location of Jumpers and Adjustment Potentiometers (Top View)

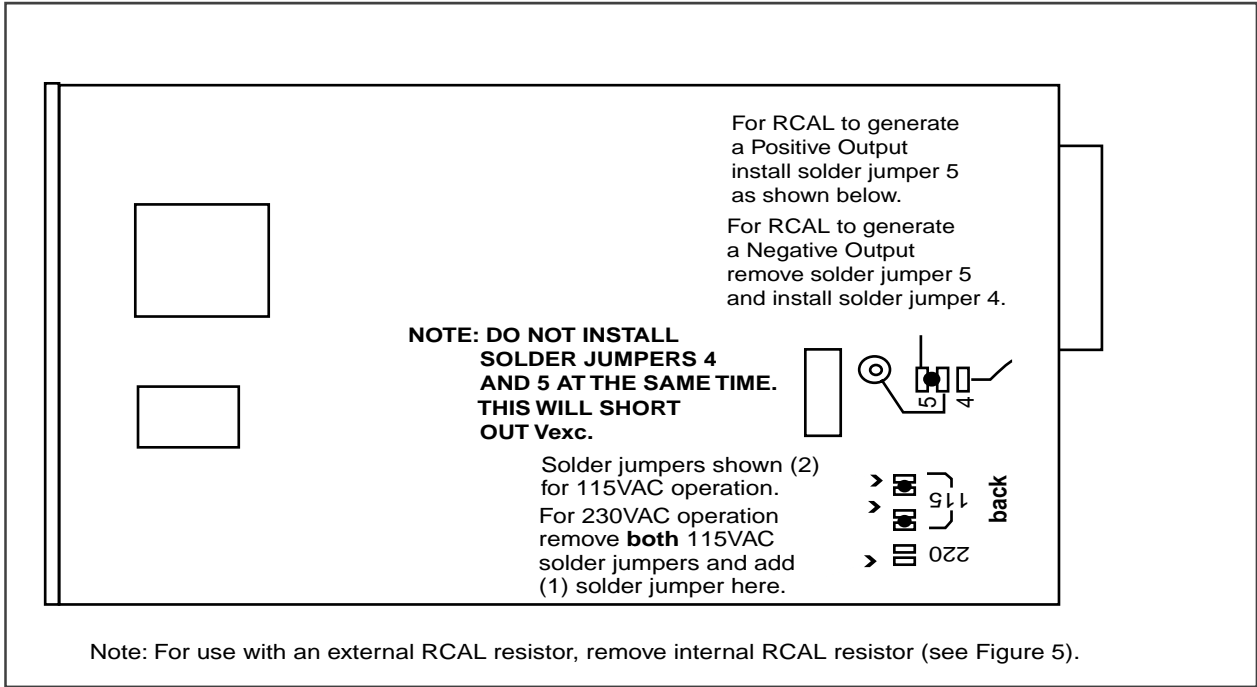
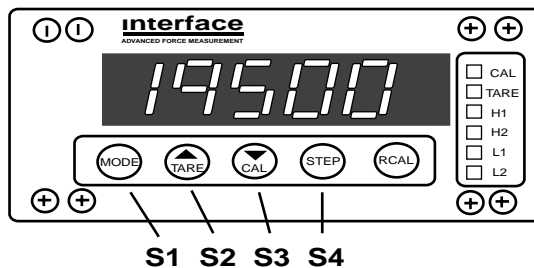

Figure 5. Location of Jumper (Bottom View)

SWITCH AND FUNCTION DEFINITIONS

SWITCH DEFINITIONS



Mode Selection Switch (S1)

S1 is used to cycle through the various setpoints, hysteresis, and calibration values and decimal point locations. The sequence is as follows. The designators, in parenthesis, identify text that will be displayed, momentarily, followed by the value.

- Set Point High 1 (SPH1)
- Set Point Low 1 (SPL1)
- Set Point High 2 (SPH2)
- Set Point Low 2 (SPL2)
- Hysteresis High (HH)
- Hysteresis Low (HL)
- Auto Cal (CAL)
- Decimal Point (dP)
- Exit

While in the Mode Selection sequence, the indicator is no longer monitoring the input signal. To exit, depress S1, once, after the Decimal Point selection is completed.

Increment or Tare Switch (S2)

This switch serves two functions, depending on the present status of S1. If the instrument is in the Mode Selection sequence, this switch increments the flashing digit.

If the instrument is in its normal operating mode, S2 becomes the TARE switch. If the TARE LED, located on the front panel, is not illuminated, depressing S2 once will automatically zero the readout and illuminate the TARE LED. Depressing S2 again will UNTARE the readout and extinguish the TARE LED. TARING is accomplished by storing the reading prior to TARING and subtracting this value from all subsequent readings.

SWITCH DEFINITIONS (CONT)

Decrement or Calibrate Switch (S3)

This switch serves two functions, depending on the present status of S1. If the instrument is in the Mode Selection sequence, this switch will decrement the flashing digit.

If the instrument is in its operating mode, S3 becomes an AUTO CAL switch. *CAUTION: Depressing this switch will cause the instrument to recalibrate its full scale reading. Be sure to read the CALIBRATION INSTRUCTIONS before using this switch.*

Step Switch (S4)

This switch also serves two functions, depending on the present status of S1. If the instrument is in the Mode Selection sequence, this switch allows the user to cycle through the digits. Used in conjunction with S2 and S3, it allows rapid updating of the Set Point, Hysteresis and Cal values.

If the instrument is in the operating mode, S4 recalls the max (Hi) and min (Lo) values.

RCAL Switch (S5)

This switch activates a reed relay, which places a fixed resistor across Sig(-) and Vexc(-) for a positive RCAL reading, or across Sig(+) and Vexc(-) for a negative RCAL reading. Solder jumpers 4 and 5 determine which RCAL reading is generated (Reference Figure 6).

Front Panel Switch Disable Jumper (Reference Figure 5)

Jumper 1, when removed, disables the CAL Switch (S3).

Jumper 2, when removed, disables the MODE Switch (S1).

FUNCTION DEFINITIONS

Set Point High 1 (SPH1)

SPH1 is the present value being constantly compared with the displayed reading. If the magnitude and sign of the reading *exceeds* the present SPH1 value, the front panel LED (H1) will illuminate. If the displayed reading equals the SPH1 value, nothing will happen. If SPH1 is exceeded, the readout must then drop below SPH1 less the Hysteresis High (HH) value before the H1 LED turns off.

Set Point Low 1 (SPL1)

SPL1 is another preset value being constantly compared with the displayed reading. If the magnitude and sign of the displayed reading *is less* than the SPL1 present value, the front panel LED (L1) will illuminate. If the displayed reading equals the SPL1 value, nothing will happen. If the displayed reading drops below SPL1, it must then exceed SPL1 plus the Hysteresis Low (HL) value before the L1 LED turns off.

Set Point High 2 (SPH2)

SPH2 is independent and functions identically to SPH1. SPH2 has its own front panel LED (H2).

Set Point Low 2 (SPL2)

SPL2 is independent and functions identically to SPL1. SPL2 has its own front panel LED (L2).

Hysteresis High (HH)

HH is the hysteresis value for SPH1 and SPH2. The hysteresis value determines the number of counts the displayed reading must fall below SPH1 and SPH2 values before deactivating their respective LEDs. The maximum value of hysteresis is 99 counts while the minimum is 00 counts.

FUNCTION DEFINITIONS (CONT)

Hysteresis Low (HL)

HL is the hysteresis value for SPL1 and SPL2. The hysteresis value determines the number of counts the displayed reading must exceed SPL1 and SPL2 values before deactivating their respective LEDs. The maximum value of hysteresis is 99 counts while the minimum is 00 counts.

Auto Cal (CAL)

This input allows the user to calibrate the full scale readout to any desired engineering units. The CAL number is entered in the same way as the Set Point and Hysteresis values. This input must be entered prior to performing the calibration. The CAL number may be any number from 1 to 99,999. Zero is an invalid CAL number. For best stability and performance, keep the maximum CAL number below 19,999 counts.

Decimal Point (dP)

dP allows selection of decimal point locations for display. The locations selectable are x.xxxx, xx.xxx, xxx.xx, xxxx.x and xxxxx.

Min/Max Recall (HI/LO)

The HI and LO values are the maximum and minimum values, respectively, of the displayed readings. Sign and magnitude are constantly compared with the displayed readings at the instrument update rate. The maximum value is initialized to -99,999 and the minimum value to 99.999 each time the TARE switch (S2) is depressed, whether to TARE or UNTARE the readout.

OPERATING INSTRUCTIONS

TURN-ON INSTRUCTIONS

Reference Figures 3 and 4 for proper input and output signal wiring.

1. Apply power to the instrument.
2. Verify the instrument readout blanks momentarily, then displays the value of the input signal.

PROGRAM INSTRUCTIONS

Four front panel switches (S1, S2, S3 and S4) allow the user to program Set Point, Hysteresis, Calibration Number (CAL) and Decimal Points and to monitor minimum, maximum or real time values.

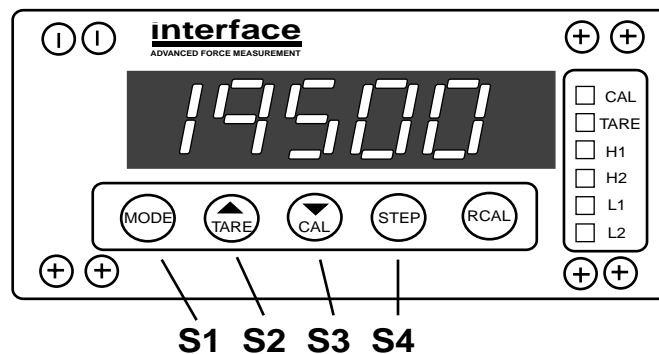

1. Depress MODE (S1) switch once.

The text **SPH1** followed by the current value of Set Point High 1 (SPH1) will be displayed. The system will idle in this condition until S2, S3 or S4 is depressed. If S2 or S3 is depressed, the most significant digit will be incremented (S2) or decremented (S3). Incrementing the most significant digit will display numbers from -9 to 9.

Depressing S4 will select the next least significant digit position for updating. The digit being updated will be flashing. Using S2, S3, and S4, set Set Point High 1 to the desired value.

PROGRAM INSTRUCTIONS (CONT)

2. Depress MODE (S1) switch once.

The text **SPL1** followed by the current value of Set Point Low 1 will be displayed. Repeat Step 1 to set Set Point Low 1 to the desired value.

3. Depress MODE (S1) switch once.

The text **SPH2** followed by the current value of Set Point High 2 will be displayed. Repeat Step 1 to set Set Point High 2 to the desired value.

4. Depress MODE (S1) switch once.

The text **SPL2** followed by the current value of Set Point Low 2 will be displayed. Repeat Step 1 to set Set Point Low 2 to the desired value.

5. Depress MODE (S1) switch once.

The text **HH** followed by the current value of Hysteresis High will be displayed. Repeat Step 1 to set Hysteresis High to the desired value. The maximum value for HH is 99 counts.

6. Depress MODE (S1) switch once.

The text **HL** followed by the current value of Hysteresis Low will be displayed. Repeat Step 1 to set Hysteresis Low to the desired value. The maximum value for HL is 99 counts.

7. Depress MODE (S1) switch once.

The text **CAL** followed by the current CAL number will be displayed. Repeat Step 1 to set the CAL number. The maximum CAL number is 99,999.

PROGRAM INSTRUCTIONS (CONT)

8. Depress MODE (S1) switch once.

The text **dP** followed by the current decimal position will be shown flashing. Increment (S2) or decrement (S3) the decimal point to the desired location.

9. Depress MODE (S1) switch once.

The instrument will exit the Mode Selection Sequence and enter the normal operating mode (i.e. monitoring the input signal) This is the end of the PROGRAM INSTRUCTIONS.

CALIBRATION INSTRUCTIONS

The Interface Model 9820 can be calibrated using (2) different methods.

1. The first method uses actual or simulated ZERO and FULL SCALE (FS) inputs. Actual inputs may come from a strain gage transducer loaded with calibrated weights. Simulated inputs may come from a strain gage bridge simulator.
2. The second method utilizes an RCAL resistor to simulate a load on a strain gage bridge. The RCAL resistor is activated when the RCAL (S5) switch is depressed. Reference Figure 3 for location of S5.

ACTUAL OR SIMULATED LOAD METHOD

1. Connect the strain gage transducer to the instrument using Figure 3 as a reference. Do not apply any load to the transducer.
2. Apply power to the instrument.

NOTE: If the instrument was previously calibrated and no new calibration is required, do not proceed any further. All previous calibration information is stored in non-volatile EEPROM and is ready for use when power to the instrument is reapplied.

3. Calculate the CAL NUMBER by verifying the load that will be used to calibrate the full scale of the Model 9820.

Example: If a 500 pound load is used to calibrate full scale and the desired readout is 500.0, the CAL NUMBER will be 5000. The decimal point can be selected later. If the desired readout is 500 then the CAL NUMBER will be 500.

4. Program in the CAL NUMBER. Reference **PROGRAM INSTRUCTIONS**, Step 7. If the CAL NUMBER was previously programmed, skip this step.

CALIBRATION INSTRUCTIONS (CONT.)

5. The TARE and CAL LED's on the front panel should be illuminated.
6. Depress the TARE(S2) switch once. The TARE LED should extinguish. The instrument should now display the UNTARED reading.
7. Depress the CAL (S3) switch once. Hold for 3 seconds. The CAL LED should extinguish. The instrument should now display the UNCALIBRATED reading.
8. With no load on the transducer, verify the instrument reading is low.
9. Depress the TARE(S2) switch once. The TARE LED should illuminate and the readout should be ZERO +/- 1 digit.
10. Apply the FULL SCALE load to the transducer. If a strain gage simulator is used, set it to the the desired mV/V setting. The instrument should display a value greater than **01000**. For optimum performance the readout should be closer to **19000**. Ignore decimal point.
11. Depress the CAL (S3) switch once. Hold for 3 seconds. The CAL LED should turn on and the readout should display the CAL NUMBER +/- 1 digit.
12. The CALIBRATION sequence is now complete.

NOTE:

Calibration values (tare and slope values) are maintained in non-volatile memory and are updated every time CALIBRATION Steps 9 and 11 are performed. TARING the display does not change the scale factor (slope value) calculated when Step 11 is completed.

S3 has a 3 second delay feature to prevent inadvertent loss of calibration.

CALIBRATION INSTRUCTIONS (CONT.)

RCAL METHOD

1. Connect the strain gage transducer to the instrument using Figure 3 as a reference. Do not apply any load to the transducer.
2. Verify that either an internal or external RCAL resistor is provided with the instrument. If an internal RCAL resistor is provided, no installation is required. Proceed to Step 3. If an external RCAL resistor is provided, install it across pins 5 and 6 (Positive Reading) or pins 5 and 7 (Negative Reading). Verify internal RCAL resistor is removed.

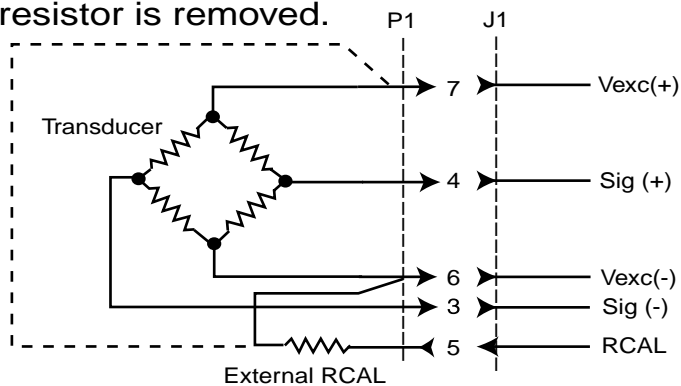

3. Apply power to the instrument.

NOTE: If the instrument was previously calibrated and no new calibration is required, do not proceed any further. All previous calibration information is stored in non-volatile EEPROM and is ready for use when power to the instrument is reapplied.

4. Set the CAL NUMBER to the full scale value provided with the RCAL resistor.

Example: If the RCAL resistor supplied with the instrument creates an output equivalent to 80% of a full scale 500 pound load, set the CAL NUMBER to 400.00, 0400.0 or 00400.

CALIBRATION INSTRUCTIONS (CONT.)

5. The TARE and CAL LED's on the front panel should be illuminated.
6. Depress the TARE (S2) switch once. The TARE LED should extinguish. The instrument should now display the UNTARED reading.
7. Depress the CAL(S3) switch once. (Hold for 3 seconds) The CAL LED should extinguish. The instrument should now display the UNCALIBRATED reading.
8. With no load on the transducer, verify the readout is approximately zero.
9. Depress the TARE(S2) switch once. The TARE LED should illuminate and the readout should be ZERO +/- 1 digit.
10. Depress and hold the RCAL switch. The display should read a value greater than **01000**. For optimum performance the readout should be closer to **19000**. Ignore decimal point.

While holding down the RCAL switch, depress the CAL (S3) switch once. The CAL LED should turn on and the readout should display the CAL NUMBER +/- 1 digit.

11. The RCAL CALIBRATION sequence is now complete.

NOTES:

Calibration values (tare and slope values) are maintained in non-volatile memory and are updated every time CALIBRATION Steps 9 and 10 are performed. TARING the display does not change the scale factor (slope value) calculated when Step 10 is completed.

S3 has a 3 second delay feature to prevent the inadvertent loss of calibration.

MODEL 9820 PROGRAM MENU DIAGRAM

SETUP PROCEDURE

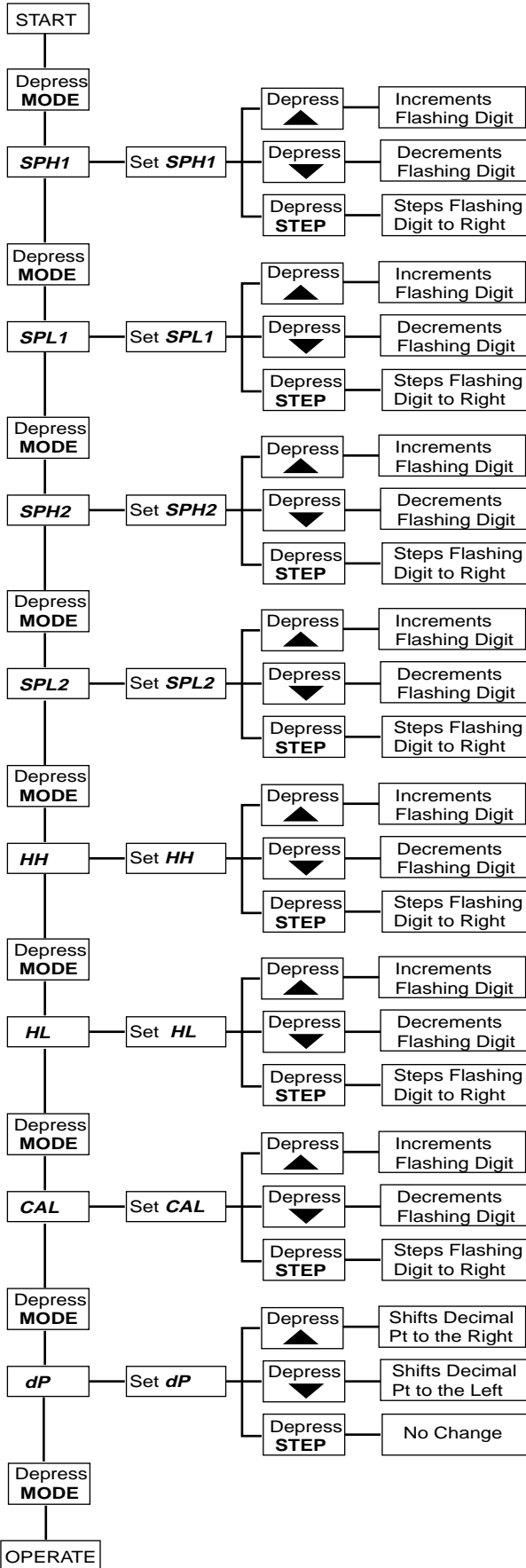

CALIBRATION PROCEDURE USING ACTUAL OR SIMULATED LOADS

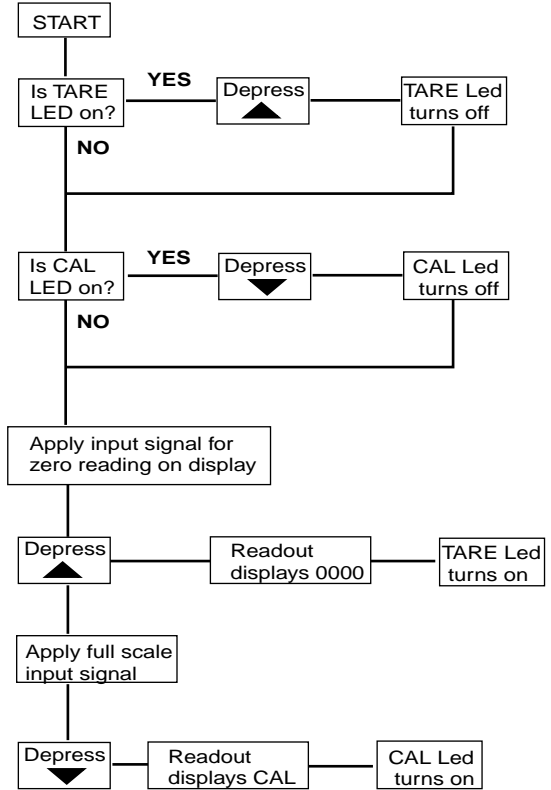

CALIBRATION PROCEDURE USING RCAL RESISTOR

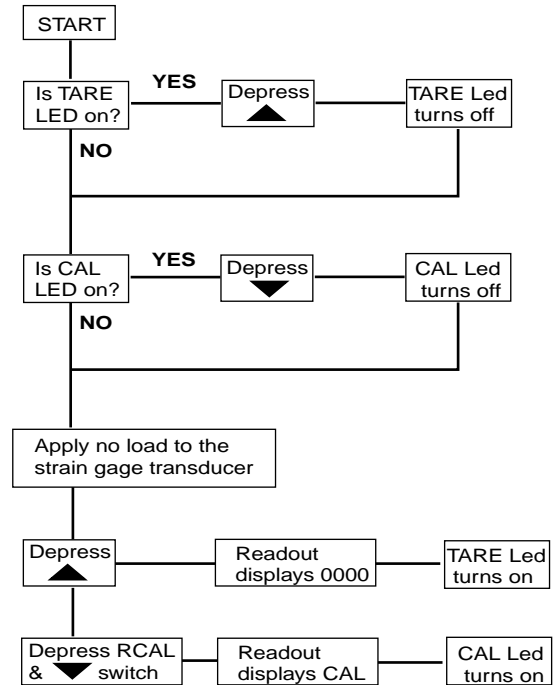

Warranty and Repair Policy

1. Interface warrants that its instruments shall be free from defects in material and workmanship for one year under normal and proper use when correctly installed.
2. Any Interface product which proves defective in material or in workmanship within one year from date of shipment by Interface, will be repaired or replaced free of charge provided that (1) buyer provides Interface with satisfactory proof of the defect and that the product was properly installed, maintained, and operated within the limits of rated and normal usage; (2) buyer obtains from Interface authorization to return the product; and (3) products claimed to be defective must be returned with transportation charges prepaid. Product will be returned to Buyer with transportation charges collect unless the item is found to be defective, in which case Interface will pay the return transportation charges.
3. The remedy set forth herein does not apply to damage to or defects in any product caused by the Buyer's misuse or neglect, nor does it apply to any product which has been repaired or disassembled, which in the sole judgement of Interface affects the performance of the product.
4. Interface makes no warranty concerning components not manufactured by it. However, in the event of the failure of any component or accessory not manufactured by Interface, reasonable assistance will be given to Buyer in obtaining from the respective manufacturer whatever adjustment is reasonable based on the manufacturer's own warranty. Interface expressly disclaims any liability to its customers, dealers, and representatives, and to users of its products, and to any other person for special or consequential damages of any kind and from any cause whatsoever arising out of or in any way connected with the manufacture, sale, handling, repair, maintenance, or replacement arising out of or in anyway connected with the use of said products.
5. Representations and warranties made by any person, including dealers and representatives of Interface, which are inconsistent or in conflict with the terms of this warranty (including but not limited to the limitations of the liability of Interface, as set forth above), shall not be binding upon Interface unless reduced to writing and approved by an officer of Interface, Inc.

THIS EXPRESS WARRANTY SUPERCEDES ANY AND ALL OTHER WARRANTIES, EXPRESSED OR IMPLIED, INCLUDING IMPLIED WARRANTY OF MERCHANTABILITY OR FITNESS FOR PARTICULAR PURPOSE.

OBTAINING SERVICE UNDER WARRANTY

Advance authorization is required before any product is returned to Interface. Prior to the return of any product, write or call the Repair Department at Interface advising them of; (1) a part number; (2) a serial number of the defective product; (3) a technical description of the defect including specific test data, written observations on the failure and specific corrective action required; (4) a no-charge purchase order number (so the product can be returned to sender correctly); and (5) ship and bill addresses. Non-verified problems or defects may be subject to an evaluation charge. Please return the original calibration data with the unit.

REPAIR WARRANTY

All repairs of Interface products are warranted for a period of 90 days from date of shipment. This warranty applies only to those items which were found defective and repaired. It does not apply to products in which no defect was found and returned as is or merely recalibrated. Out of warranty products may not be capable of being

interface

ADVANCED FORCE MEASUREMENT

7401 E. BUTHERUS DR. • SCOTTSDALE, AZ 85260

TEL: (480) 948-5555 FAX: (480) 948-1924

www.interfaceforce.com

