

Electrical Information

Load Cell Series	Cell Type	Upscale (4) Mode	Integral Cable Wiring	Std. Cable Type	Cable Length, Feet (5)	Connector Wiring	Mating Connector (2)
1000	Univ.	Tension	Fig. W1	A	10	Fig. C1	PC06W-10-6S(SR)
1100	Univ.	Tension	Fig. W1	A	10	Fig. C1	PC06W-10-6S(SR)
1100	Comp.	Tension	Fig. W1	A	10	Fig. C1	PC06W-10-6S(SR)
1200	Univ.	Tension	Fig. W1	A	10	Fig. C1	PC06W-10-6S(SR)
1200	Comp.	Comp.	Fig. W1	A	10	Fig. C1	PC06W-10-6S(SR)
1500	Univ.	Tension	—	—	—	Fig. C1	PT06A-10-6S(SR)
1600	Univ.	Tension	—	—	—	Fig. C2	PT06A-12-8S(SR)
1600	Comp.	Tension	—	—	—	Fig. C2	PT06A-12-8S(SR)
1700	Univ.	Tension	—	—	—	Fig. C6	PT06A-10-6S(SR)
1800	Univ.	Tension	—	—	—	Fig. C2	PT06A-12-8S(SR)
3200	Univ.	Tension	Fig. W2	B	20	—	—
3200	Comp.	Tension	Fig. W2	B	20	—	—
4200	Comp.	Tension	Fig. W2	B	20	—	—
4600	Comp.	Tension	Fig. W2	B	20	—	—
5200	Univ.	Tension (1)	Fig. W1	A	10	Fig. C1	PC06W-10-6S(SR)
SSB	Comp.	Comp.	Fig. W2	C	5	—	—
MB, MBP	Comp.	Comp.	Fig. W2	C	5	—	—
SM	Univ.	Tension	Fig. W2	C	5	—	—
SSM	Univ.	Tension	Fig. W2	A	10	Fig. C1	PC06W-10-6S(SR)
SMT	Univ.	Tension	Fig. W2	D	5	—	—
SPI	Univ.	Comp.	Fig. W2	C	5	—	—
SML	Univ.	Tension	Fig. W2	D	5	—	—
LBM	Comp.	Tension	Fig. W2	G	5	—	—
LBS	Comp.	Tension	Fig. W2	G	5	—	—
LoadCheck	Comp.	Tension	Fig. W1	A	10	—	—
LoadTrol	Comp.	Comp.	—	Note (3)	Note (3)	Note (3)	Note (3)
LW	Comp.	Comp.	Fig. W2	—	5	—	—
WeighCheck	Comp.	Tension	Fig. W2	B	30	—	—
WMC	Univ.	Tension	Fig. W3	G	—	—	—
WMC ≥15K	Univ.	Tension	—	—	—	Fig. C3	PT06A-10-6S(SR)
2410-2430	Univ.	Tension	—	—	—	Fig. C3	PT06A-10-6S(SR)
2440-2450	Univ.	Tension	—	—	—	Fig. C3	MS3106A-145-6S
2100	Univ.	Tension	—	—	—	Fig. C4	MS3106A-145-5S
2100	Comp.	Tension	—	—	—	Fig. C4	MS3106A-145-5S
MRT	Torque	CW	W2	D	5	—	—
ULC	Univ.	Tension	W2	D	5	—	—
MCC	Comp.	Comp.	W2	E	5	—	—
CX	—	—	—	—	—	Fig. C5	PT06A-12-8S(SR)

Notes: (1) Thrust axis only.

(2) Mating connector for the stock version of cell. Consult factory for alternate connectors and specials.

(3) Consult factory. Several connectors and mating cable types are available.

(4) Indicates the loading direction which causes a positive output.

(5) Stock length; other lengths available on special order.

LOAD CELL INTEGRAL CABLES

Cable Type	Wire Size	No. of Wires	Shield	Description
A	22 AWG	7	Braid	Heavy-duty, PVC jacket
B	22 AWG	4	Braid	Heavy-duty, polyurethane jacket
C	28 AWG	4	Braid	Tough, clear PVC jacket
D	28 AWG	4	Spiral	Ultra-flexible, black PVC jacket
E	30 AWG	4	Braid	Ultra-flexible, gray PVC jacket
F	20 AWG	4	Braid	Teflon jacket
G	30 AWG	4	Braid	Teflon jacket

Wiring Diagrams

LOAD CELL CABLE WIRING

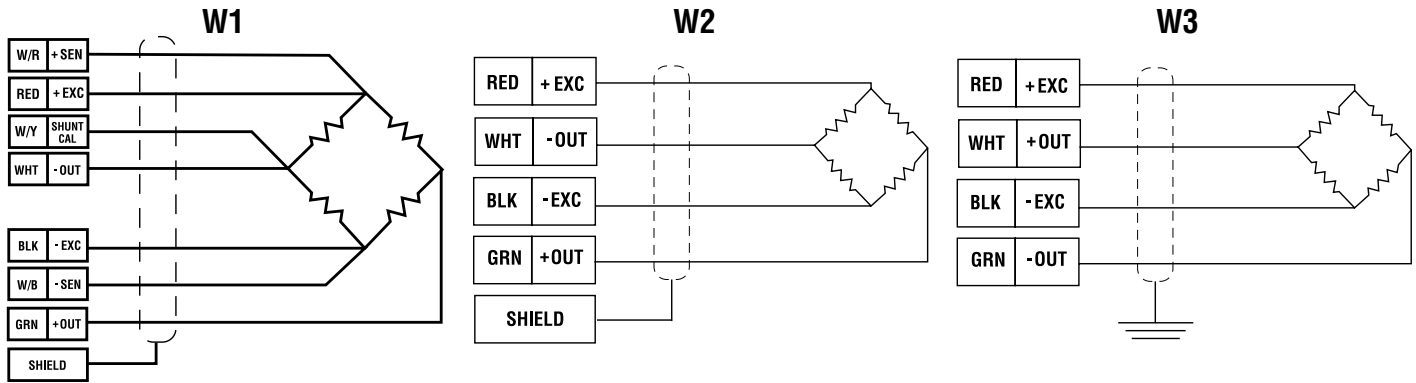

LOAD CELL CONNECTOR WIRING

