

# T2, T3, T4, T5, T6, T7, T12 & T15 Rotary Torque Transducers *Operation Manual*



T2 Precision Rotary &  
T4 General Purpose Rotary  
Torque Transducers



T3 Precision Rotary &  
T5 General Purpose Rotary  
Torque Transducers



T6 Dual Range  
Rotary Torque Transducer



T7 Dual Range  
Rotary Torque Transducer



T12 Square Drive  
Rotary Torque Transducer



T15 Hex Drive  
Rotary Torque Transducer

Valid for...	T2, T3, T4, T5, T6, T7, T12 & T15 Rotary Torque
Copyright	© 2009 Interface, Inc.
Modification	Technical changes reserved.

## References in this Text

### 1.6 Warning Notes; Page 5



Attention must be paid to the accident prevention regulations of the trade associations. Coverings and casings are necessary before operating the transducer. This is also valid for commissioning, maintenance and troubleshooting.

Duties of the coverings and casings are:

- ⇒ Protection from detaching parts
- ⇒ Protection from contusion and shear
- ⇒ Prevention from reaching rotating parts
- ⇒ Prevention from being tangled up and/or getting caught by parts

Coverings may:

- ⇒ Not grind
- ⇒ Not rotate

Coverings are also necessary outside of operating and motion travel areas of persons. These demands can be modified if other sufficient safety devices are available. During operation, the safety precautions must be operative. By vibrations, damages can occur on the device.

### 5 Mechanical Assembly; Page 10



During the assembly, the transducer must be supported to protect it from falling down.

#### 5.1.3 Alignment of the Measurement Arrangement; Page 10



For more information please consult factory for details. (800) 947-5598 | (480) 948-5555 or visit [www.interfaceforce.com](http://www.interfaceforce.com).

### 5.2 General; Page 10



Before the assembly, shafts must be cleaned with dissolver (i.e. acetone), no foreign particles may adhere to them. The hub must fit corresponding to the connection.



**Caution:** During the assembly inadmissibly large forces may not act on the transducer or the couplings. At small torques (< 20 Nm) connect the transducer electrically during the assembly and observe the signal, the measurement signal may not exceed the limit values.

#### 5.2.1 Torque Transducers of 0.03 Nm to 15 Nm; Page 11



Transducers with nominal torques below 20 Nm are very sensitive to overload, therefore these transducers need to be handled with greatest caution.

### 5.3 Free floating Assembly; Page 11



**Caution:** During the assembly inadmissibly large forces may not act on the transducer or the couplings.



In this installation case, double-jointed couplings cannot be used for both sides.  
**Risk of Breakage!**

### 5.4 Foot Version Assembly; Page 12



**Caution:** During the assembly inadmissibly large forces may not act on the transducer or the couplings.

### 6.1 Engaging; Page 13



Warming-up period of the torque transducer is approx. 5 min.

#### 6.4.2 Natural Resonances; Page 14



An operation of the device in natural resonance can lead to permanent damages.

**Contents**

1	Read First .....	4
1.1	Safety and Caution Symbols .....	4
1.2	Intended Use .....	4
1.3	Dangers .....	4
1.3.1	Neglecting of Safety Notes .....	4
1.3.2	Remaining Dangers .....	4
1.4	Reconstructions and Modifications .....	4
1.5	Personnel .....	4
1.6	Warning Notes .....	5
2	Term Definitions .....	5
2.1	Terms .....	5
2.2	Definition of the Pictograms on the Torque Transducer.....	5
3	Product Description .....	5
3.1	Mechanical Setup .....	5
3.2	Principle of Operation .....	6
	Electrical Setup.....	7
3.2.1	Transducers with Analog Output.....	8
3.2.2	Transducers with RS485 Interface.....	8
3.2.3	The Serial Communication .....	8
4	Electrical Connection .....	8
4.1	Pin Connection .....	8
4.2	Calibration Control.....	8
4.2.1	Calibration Control at Analog Output .....	9
4.2.2	Calibration Control at RS485 .....	9
4.3	Cable .....	9
4.4	Shielding Connection.....	9
4.5	Running of Measuring Cables .....	9
4.6	Angle/Speed (Option) .....	9
4.7	Speed Only (Option) .....	9
5	Mechanical Assembly .....	10
5.1	Couplings.....	10
5.1.1	Misalignment Possibilities of Single-Jointed Couplings .....	10
5.1.2	Double-Jointed Couplings.....	10
5.1.3	Alignment of the Measurement Arrangement .....	10
5.2	General.....	10
5.2.1	Torque Transducers of 0.03 Nm to 15 Nm .....	11
5.2.2	Torque Transducers from 20 Nm.....	11
5.3	Freefloating Assembly .....	11
5.4	Foot Version Assembly.....	12
5.5	Typical Application.....	13
6	Measuring.....	13
6.1	Engaging .....	13
6.2	Direction of Torque .....	13
6.3	Static/Quasi-Static Torques .....	13
6.4	Dynamic Torques.....	13
6.4.1	General.....	13
6.4.2	Natural Resonances .....	14
6.5	Speed Limits .....	14
6.6	Disturbance Variables.....	14
7	Maintenance .....	14
7.1	Maintenance Schedule .....	14
7.2	Troubleshooting .....	15
8	Decommission .....	15
9	Transportation and Storage.....	15
9.1	Transportation .....	16
9.2	Storage .....	16
10	Disposal.....	16
11	Calibration .....	16
11.1	Proprietary Calibration .....	16
11.2	DKD-Calibration.....	16
11.3	Recalibration.....	16

## 1 Read First

### 1.1 Safety and Caution Symbols



**Caution:**

Injury Risk for Persons  
Damage of the Device is possible.



**Note:**

Important points to be considered.

### 1.2 Intended Use

Torque transducers are intended for the measurement of torques. This measure is further suitable for control tasks. The valid safety regulations should be absolutely respected. The torque transducers are not safety components in the sense of the intended use. The transducers need to be transported and stored appropriately. The assembly, commissioning and disassembling must take place professionally.

### 1.3 Dangers

The torque transducer is fail-safe and corresponds to the state of technology.

#### 1.3.1 Neglecting of Safety Notes

At inappropriate use, remaining dangers can emerge (i.e. by untrained personnel). The operation manual must be read and understood by each person entrusted with the assembly, maintenance, repair, operation and disassembly of the torque transducer.

#### 1.3.2 Remaining Dangers

The plant designer, the supplier, as well as the operator must plan, realize and take responsibility for safety-related interests for the transducer. Remaining dangers must be minimized. Remaining dangers of the torque measurement technique must be pointed out.

Human mistakes must be considered. The construction of the plant must be suitable for the avoidance of dangers. A danger-analysis for the plant must be carried out.

### 1.4 Reconstructions and Modifications

Each modification of the transducers without our written approval excludes liability on our part.

### 1.5 Personnel

The installation, assembly, commissioning, operation and the disassembly must be carried out by qualified personnel only. The personnel must have the knowledge and make use of the legal regulations and safety instructions.

## 1.6 Warning Notes



Attention must be paid to the accident prevention regulations of the trade associations. Coverings and casings are necessary before operating the transducer. This is also valid for commissioning, maintenance and troubleshooting.

Duties of the coverings and casings are:

- ⇒ Protection from detaching parts
- ⇒ Protection from contusion and shear
- ⇒ Prevention from reaching rotating parts
- ⇒ Prevention from being tangled up and/or getting caught by parts

Coverings may:

- ⇒ Not grind
- ⇒ Not rotate

Coverings are also necessary outside of operating and motion travel areas of persons.

These demands can be modified if other sufficient safety devices are available. During operation, the safety precautions must be operative. By vibrations, damages can occur on the device.

## 2 Term Definitions

### 2.1 Terms

#### Measuring Side:

Mechanical connection of the torque transducer in which the torque to be measured is applied. Usually this side has the smallest moment of inertia.

#### Drive Side:

Mechanical connection of the torque transducer on the opposite side of the measuring side, usually with the largest moment of inertia. At static torque transducers the housing is fastened on this side.

#### Low Torque Resistance Side:

The shaft of the arrangement (drive, load) which can be turned considerably smaller with torque than the nominal torque of the torque transducer  $M \ll M_{nenn}$ .

### 2.2 Definition of the Pictograms on the Torque Transducer

The measuring side of the torque transducer is designated as follows:

Measuring side:

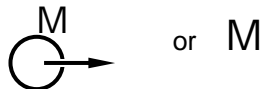

For more information consult factory (800) 947-5598 or visit [www.interfaceforce.com](http://www.interfaceforce.com)

## 3 Product Description

The transducer measures static and dynamic torques. The mounting position of the torque transducer is horizontally.

**Caution:** It is differentiated between measuring side and driving side. Consult factory for details.

### 3.1 Mechanical Setup

The transducers consist of a torsion shaft. Depending on design, the mechanical connection possibilities are executable with round shafts or feather key connections etc. The torsion shaft, applied with two strain gauge full bridges, is bedded in a housing through ball bearings. For the signal transmission and/or the supply of the strain gauge full bridges, a rotating transformer, according to the principle of a transformer, is arranged in the transducer. For supply and measuring signal conditioning, electronics are integrated in the stator and the rotor.

### 3.2 Principle of Operation

The supply voltage of between 12 and 28V DC is converted to AC in the stator and transferred inductively to the rotor electronics. The voltage is rectified and stabilized and fed to the strain gage bridge. The output of the bridge is conditioned in an amplifier and then converted to a digital signal, which is transferred to the stator by another rotating transformer. This digital signal is much more disturbance-free than an analog signal and is highly immune to noise. This signal is further conditioned in the stator, comes into a  $\mu$ -processor and then is converted to the  $\pm 5$  or  $\pm 10$ V output signal.

These transducers feature internal **Shunt Calibration Resistors** that can be switched into the bridge. A voltage of greater than 3.5V to pin K causes a control signal to be up-modulated to the supply voltage and transferred to the rotor. There, it is filtered and evaluated by the  $\mu$ PC, which then activates the internal switch for the connection of the R-Cal resistor.

#### Initial Calibration

1. A preliminary calibration of the strain gaged shaft determines the bridge full scale output in mV/V.
2. A shunt resistor value is created to provide an output equal to the full scale output of the strain gage bridge.
3. The resistor is then hard-wired through a switch into the bridge.
4. Final assembly includes installation of the rotating shaft into the stator housing.
5. After final assembly the complete sensor is calibrated by applying known torques and adjusting the full scale output to  $\pm 5$ V or  $\pm 10$ V.
6. A calibration certificate is generated showing the transducer full scale output in Volts and the R-Cal Calibration Signal output in both volts and units of torque.

#### Field R-Cal System Calibration

1. Apply between 3.5V-28V to pin K of the transducer. Pin K should be connected through a switch to either the supply voltage or another voltage source.
2. A Calibration Signal will be generated equal to the torque value listed on the calibration certificate. The Customer's data acquisition system can then be scaled using this signal.

## Electrical Setup

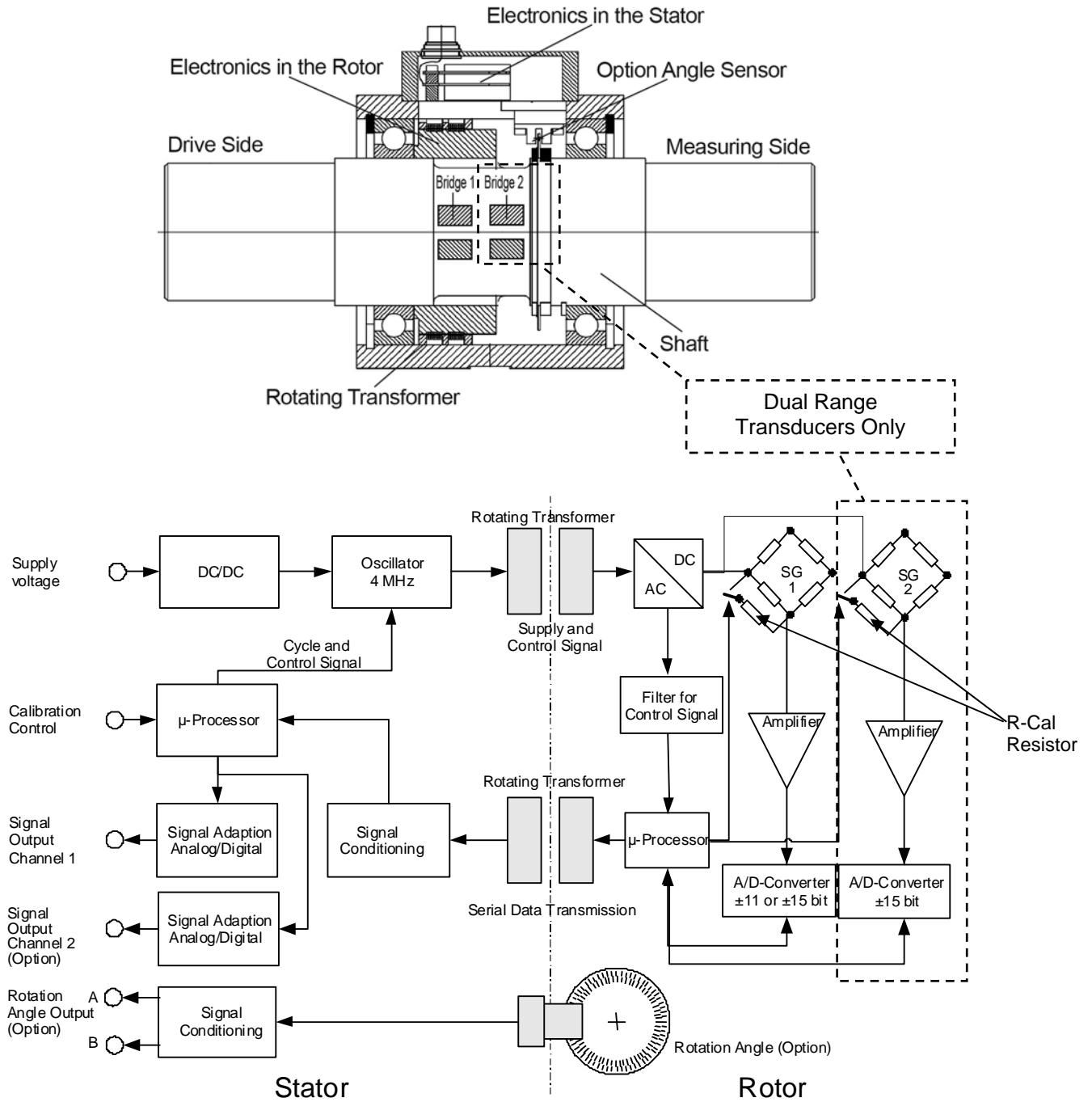

Block diagram for serial signal transmission

### 3.2.1 Transducers with Analog Output

At this output, the digital signal is converted into DC voltage of  $\pm 5V$  or  $\pm 10V$ , proportional to the torque and is available at the connector output.

### 3.2.2 Transducers with RS485 Interface

The torque transducer has a digital interface RS485 for the signal output and automatic transducer identification.

The protocol enables high dynamics.

For more information consult factory (800) 947-5598 or visit [www.interfaceforce.com](http://www.interfaceforce.com).

### 3.2.3 The Serial Communication

Consult factory (800) 947-5598 or visit [www.interfaceforce.com](http://www.interfaceforce.com).

## 4 Electrical Connection

### 4.1 Pin Connection

Also see test certificate.

8-pin	Analog	
1	Excitation +	12 ... 28 VDC
2	Excitation GND	0V
3	Signal	$\pm 5V / (\pm 10V)$
4	Signal GND	0V
5	Calibration control	L<2.0V; H>3.5V
6	Option angle A	TTL
7	Option angle B	TTL
8	NC	

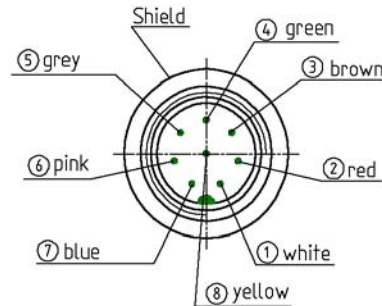

For color code of black molded one-piece cable assembly please consult factory.

12-pin	Analog		Digital	
A	NC		NC	
B	Option angle B	TTL	Option angle B	TTL
C	Signal	$\pm 5V / (\pm 10V)$	NC	
D	Signal GND	0V	NC	
E	Excitation GND	0V	Excitation GND	0V
F	Excitation +	12 ... 28 VDC	Excitation +	12 ... 28 VDC
G	Option angle A	TTL	Option angle A	TTL
H	NC		NC	
J	NC		Output B	RS485
K	Calibration control	L<2.0V; H>3.5V	NC	
L	NC		Output A	RS485
M	Housing		Housing	

View: socket on soldering side

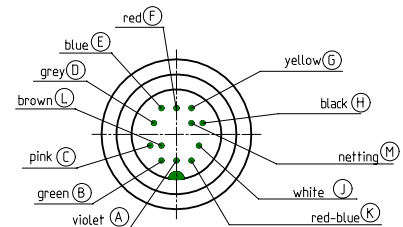

### 4.2 Calibration Control

Only use calibration control in unloaded condition of the torque transducer. Cal control output is approximately equal to transducer full scale output. Exact value is noted on calibration certificate.

#### 4.2.1 Calibration Control at Analog Output

Applying voltage of between +3.5V to +28V switches the calibration control on. Voltage below +2.0V switches it off.



#### 4.2.2 Calibration Control at RS485

The calibration control switch on is carried out by a command. For more information consult factory (800) 947-5598 or visit [www.interfaceforce.com](http://www.interfaceforce.com).

#### 4.3 Cable

Use only shielded cable with the shortest length possible. We recommend Interface brand cables as they are tested together with our transducers.

#### 4.4 Shielding Connection

In combination with the transducer and the external electronics, the shield forms a Faraday Cage. By this, electro-magnetic disturbances do not have any influence on the measurement signal.

#### 4.5 Running of Measuring Cables

Do not run measuring cables together with control or heavy-current cables. Always assure that a large distance is kept to engines, transformers and contactors, because their stray fields can lead to interferences of the measuring signals.

If troubles occur through the measuring cable, we recommend running the cable in a grounded steel conduit.

#### 4.6 Angle/Speed (Option)

360 pulse/revolution, 2-track, +5V TTL. The second track can be used to quadruple the number of pulses/revolution, or to determine rotation direction. Not available on transducers above 1,000 Nm

#### 4.7 Speed Only (Option)

60 pulse/revolution, single track, +5V TTL. Available on transducers above 1,000 Nm only.

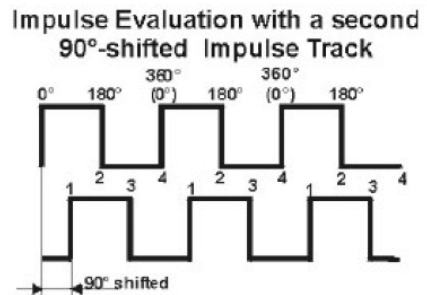

## 5 Mechanical Assembly

For the assembly of a torque transducer in a shaft line, we always recommend to use couplings, which can be misaligned.



During the assembly, the transducer must be supported to protect it from falling down.

### 5.1 Couplings

We recommend multi-disc couplings for our torque transducers. Couplings must be able to balance an axial, radial or angular offset of the shafts and not allow large forces to act on the transducer. The assembly instructions of the respective coupling manufacturer must be considered.

#### 5.1.1 Misalignment Possibilities of Single-Jointed Couplings

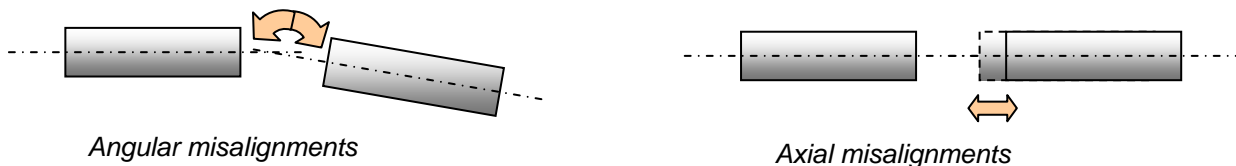

**Note:** Radial misalignments are only possible in the combination of single-jointed coupling - torque transducer (as adapter) - single-jointed coupling. Thus, with both single-jointed couplings the torque transducer forms a double-jointed coupling.

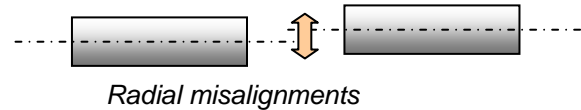

#### 5.1.2 Double-Jointed Couplings

Double-jointed couplings are used for the balance of inevitable angular, axial and radial misalignments.

#### 5.1.3 Alignment of the Measurement Arrangement

Precisely alignment of the couplings reduces the reaction forces and increases the durability of the couplings. Disturbance variables are minimized as well.

Due to the multitude of applications, an alignment of the coupling with a straight edge in two levels, vertical to each other, is sufficient.

However, in drives with high speed, an alignment of the coupling (shaft ends) with a dial gauge or a laser is recommended.

### 5.2 General



Before the assembly, shafts must be cleaned with dissolver (i.e. acetone); no foreign particles may adhere to them. The hub must fit corresponding to the connection.

#### Connections with Clamping Piece:

The indications of the clamping piece manufacturer must be considered. The clamping piece must be able to transfer the arising torques safely.



**Caution:** During the assembly inadmissibly large forces may not act on the transducer or the couplings. At small torques (< 20 Nm) connect the transducer electrically during the assembly and observe the signal, the measurement signal may not exceed the limit values.

### 5.2.1 Torque Transducers of 0.03 Nm to 15 Nm



Transducers with nominal torques below 20 Nm are very sensitive to overload, therefore these transducers need to be handled with greatest caution.

1. Connect the transducer electrically during the assembly and observe the measuring signal; the limit values may not be exceeded in any case.
2. Align the arrangement before the parts are connected firmly.
3. Assemble the transducer at the **low torque resistance side** first, then at the stationary side (this avoids impermissibly large torques from acting on the transducer).
4. Counter-hold by hand, so that impermissibly large torques or disturbance variables can not act on the torque transducer.

### 5.2.2 Torque Transducers from 20 Nm

The hub must fit corresponding to the connection.

### 5.3 Freefloating Assembly

The transducer is installed between two single-jointed couplings and contributes to the balance of an inevitable axis offset between the two mechanical connections.

If no couplings are used, very large transverse forces can affect the transducer. In addition, large forces occur on the bearings in drive and output, which limit their life span very strongly.

Shift couplings on shafts (use entire clamping length of the coupling) and align shafts. Assure absolutely that the data of the couplings (axis offset, angular offset, tension, compression) are not exceeded.

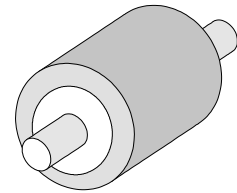

**Caution:** During the assembly inadmissibly large forces may not act on the transducer or the couplings.

The housing must be protected from twisting i.e. by a flexible connection. The cable connection may not be used for this.

The cable connection must be placed loosely (form of goose neck), so that it can follow the light movements of the stator.

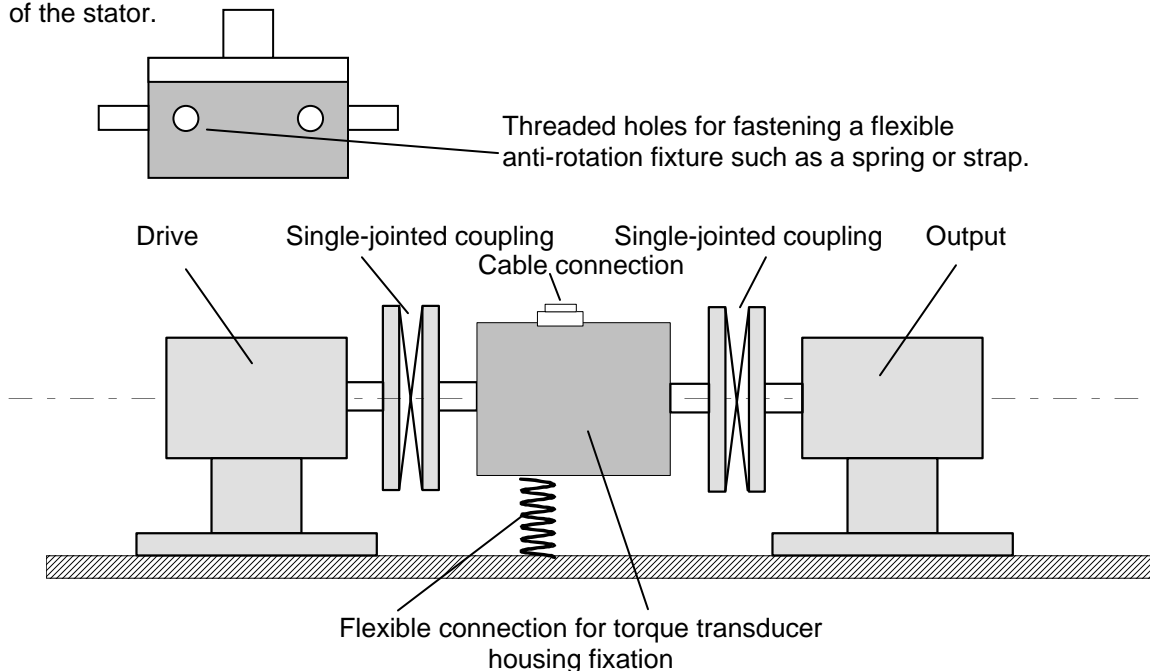

In this case, with both single-jointed couplings, the torque transducer forms a double-jointed coupling. A single-jointed coupling can only balance axial and angular misalignments.



In this installation case, double-jointed couplings cannot be used for both sides!  
**Risk of Breakage!**

## 5.4 Foot Version Assembly

The housing of the transducer is designed as a bearing block. A full coupling must be installed at both shaft ends. By this, inevitable misalignments can be balanced, which can occur during the period of operation.

If no couplings are used, very large transverse forces can affect the transducer. In addition, large forces occur on the bearings in drive and output, which limit their life span very strongly.

Furthermore large bending moments occur in the shaft. At small torques (< 20 Nm) connect the transducer electrically during the assembly and observe the signal, the measurement signal may not exceed the limit values

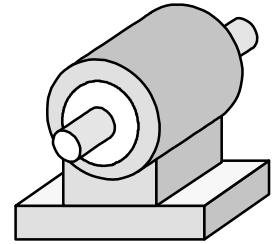

Shafts have to be cleaned with solvent (i.e. acetone) before the assembly  
 No foreign bodies may adhere to them.

Shift couplings on shaft (use entire clamping length of the coupling) and align shafts.

Absolutely note that the data of the couplings (axis offset, angular offset, tension, compression) are not exceeded.

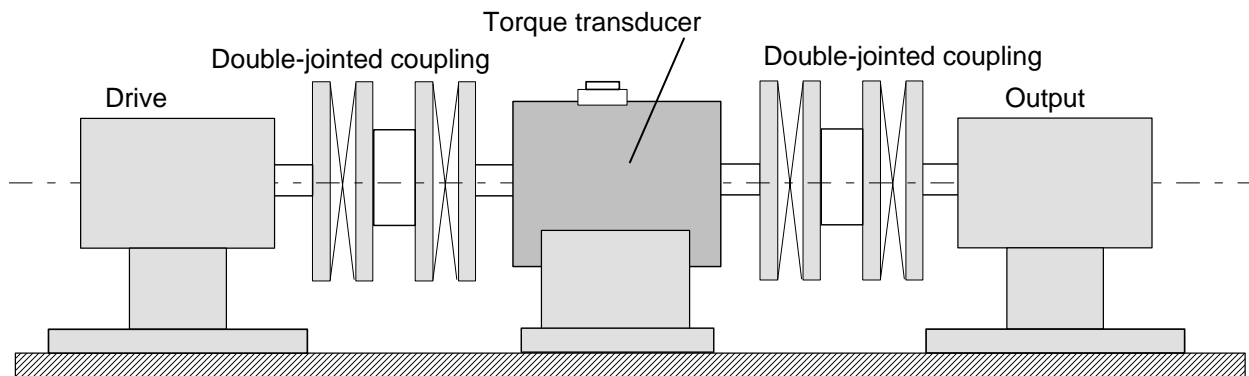

## 5.5 Typical Application

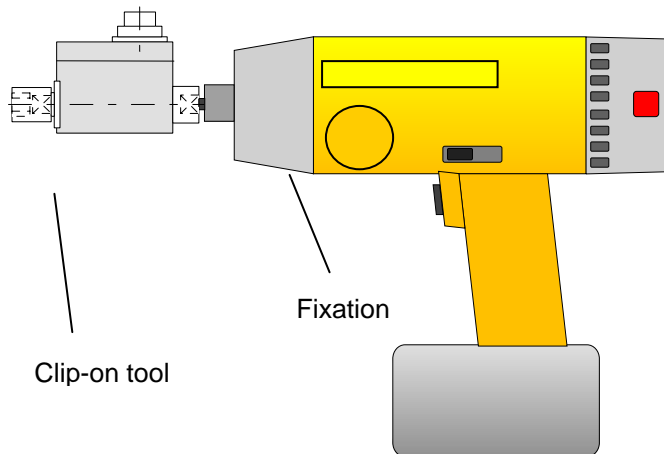

**Caution: Do not use impulse or impact screwdrivers!**

## 6 Measuring

### 6.1 Engaging

The warming-up period of the torque transducer is approx. 5 min. Afterwards the measurement can be started.



The warming-up period of the torque transducer is approx. 5 min.

### 6.2 Direction of Torque

Torque means clockwise or counter-clockwise torque if the torque acts clockwise when facing the shaft end. In this case a positive electrical signal is obtained at the output.

Torque transducers can measure both, clockwise and counter-clockwise direction.

### 6.3 Static/Quasi-Static Torques

Static and/or quasi-static torque is a slowly changing torque.

The calibration of the transducers occurs statically on a calibration device.

The applied torque may accept any value up to the nominal torque.

### 6.4 Dynamic Torques

#### 6.4.1 General

The static calibration procedure of torque transducers is also valid for dynamic applications.

**Note:** The frequency of torques must be smaller than the natural frequency of the mechanical measurement setup.

The bandwidth of alternating torque must be limited to 70% of the nominal torque.

### 6.4.2 Natural Resonances

Estimate of the mechanical natural frequencies:

$$f_0 = \frac{1}{2 \cdot \pi} \cdot \sqrt{c \cdot \left( \frac{1}{J_1} + \frac{1}{J_2} \right)}$$

$f_0$  = Natural Frequency in Hz  
 $J_1, J_2$  = Moment of Inertia in kg\*m<sup>2</sup>  
 $c$  = Torsional Rigidity in Nm/rad

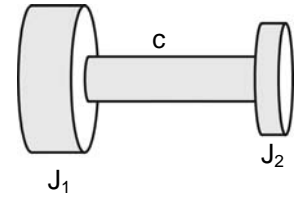

An operation of the device in natural resonance can lead to permanent damages.

### 6.5 Speed Limits

The maximum speed indicated in the data sheet may not be exceeded in any operating state.

### 6.6 Disturbance Variables

By disturbances, measured value falsifications can occur by:

- Vibrations
- Temperature gradients
- Temperature changes
- Arising disturbance variables during operation, i.e. imbalance
- Electrical disturbances
- Magnetic disturbances
- EMC (electromagnetic disturbances)

Therefore avoid these disturbance variables by decoupling of vibrations, covers, etc.

## 7 Maintenance

### 7.1 Maintenance Schedule

Action	Frequency	Date	Date	Date
Control of cables and connectors	1x p.a.			
Calibration	< 26 months			
Control of fixation (flanges, shafts)	1x p.a.			
Have bearings exchanged by Interface, Inc.	20,000 hrs operating time			

## 7.2 Troubleshooting

This chart is used for searching for the most frequent errors and their elimination

Problem	Possible Cause	Troubleshooting
No signal	No transducer excitation	<ul style="list-style-type: none"> <li>• Outside of permissible range</li> <li>• Connect excitation</li> <li>• Cable defect</li> <li>• No mains supply</li> </ul>
	Signal output connected wrong	<ul style="list-style-type: none"> <li>• Connect output correctly</li> <li>• Evaluation electronics defect</li> </ul>
Transducer does not react to torque	Shaft not clamped	<ul style="list-style-type: none"> <li>• Clamp correctly</li> </ul>
	No power supply	<ul style="list-style-type: none"> <li>• Outside of permissible range</li> <li>• Connect supply</li> <li>• Cable defect</li> <li>• No mains supply</li> </ul>
	Cable defect	<ul style="list-style-type: none"> <li>• Repair cable</li> </ul>
	Connector connected wrong	<ul style="list-style-type: none"> <li>• Connect correctly</li> </ul>
Signal has dropouts	Axial position rotor to stator outside of tolerance	<ul style="list-style-type: none"> <li>• Align rotor</li> </ul>
	Cable defect	<ul style="list-style-type: none"> <li>• Repair cable</li> </ul>
Zero point outside of tolerance	Cable defect	<ul style="list-style-type: none"> <li>• Repair cable</li> </ul>
	Shaft mounted distorted	<ul style="list-style-type: none"> <li>• Mount correctly</li> </ul>
	Distorted shaft string	<ul style="list-style-type: none"> <li>• Release from distortion</li> </ul>
	Strong lateral forces	<ul style="list-style-type: none"> <li>• Reduce lateral forces</li> </ul>
	Distorted flanges	<ul style="list-style-type: none"> <li>• Check evenness of flange-surfaces</li> </ul>
	Shaft overloaded	<ul style="list-style-type: none"> <li>• Send to manufacturer</li> </ul>
Wrong torque indication	Calibration not correct	<ul style="list-style-type: none"> <li>• Recalibrate</li> </ul>
	Transducer defect	<ul style="list-style-type: none"> <li>• Repair by manufacturer</li> </ul>
	Torque shunt	<ul style="list-style-type: none"> <li>• Eliminate shunt</li> </ul>
Oscillations	Alignment of shaft not correct	<ul style="list-style-type: none"> <li>• Align correctly</li> </ul>
	Unbalance	<ul style="list-style-type: none"> <li>• Balance the corresponding parts</li> </ul>

## 8 Decommission

All transducers must be dismantled professionally. Do not strike transducer housings with tools. Do not apply bending moments on the transducer, i.e. through levers. The torque transducer must be supported to avoid falling down during the dismantling.

## 9 Transportation and Storage

The transportation of the transducers must occur in suitable packing.

For smaller transducers, stable cartons, which are well padded, are sufficient (i.e., air cushion film, epoxy crisps, paper shavings). The transducer should be tidily packed into film so that no packing material can reach into the transducer (ball bearings).

Larger transducers should be packed in cases.

## 9.1 Transportation

Only release well packed transducers for transportation. The transducer should not be able to move back and forth in the packing. The transducers must be protected from moisture. Only use suitable means of transportation.

## 9.2 Storage

The storage of the transducers must occur in dry, dust-free rooms, only. Slightly lubricate shafts and flanges with oil before storing (rust).

## 10 Disposal

The torque transducers must be disposed according to the valid provisions of law. For more information consult factory (800) 947-5598 or visit [www.interfaceforce.com](http://www.interfaceforce.com).

## 11 Calibration

At the time of delivery, torque transducers have been adjusted and tested with traceable calibrated measuring equipment at factory side. Optionally, a calibration of the transducers can be carried out.

### 11.1 Proprietary Calibration

Acquisition of measurement points and issuing of a calibration protocol Traceable calibrated measuring equipment is being used for the calibration. The transducer data are being checked during this calibration.

### 11.2 DKD-Calibration

The calibration of the transducer is carried out according to the guidelines of the DKD. The surveillance of the calibrating-laboratory takes place by the DKD. At this calibration, the uncertainty of measurement of the torque-measuring instrument is determined. Further information can be obtained from Interface Inc.

### 11.3 Recalibration

The recalibration of the torque transducer should be carried out after 26 months at the latest.

Shorter intervals are appropriate:

- Overload of the transducer
- After repair
- After inappropriate handling
- Demand of high-quality standards
- Special traceability requirements