

# INSTRUCTION MANUAL

## MODEL 9860



**TEDS Strain Gage Indicator with  
Enhanced Performance**

**interface**

ADVANCED FORCE & TORQUE MEASUREMENT  
7401 E. Butherus Drive, Scottsdale, AZ 85260  
[www.interfaceforce.com](http://www.interfaceforce.com)

## **WARRANTY AND REPAIR POLICY**

1. Interface warrants that its instruments shall be free from defects in material and workmanship for one year under normal and proper use when correctly installed.
2. Any Interface product which proves defective in material or in workmanship within one year from date of shipment by Interface, will be repaired or replaced free of charge provided that (1) buyer provides Interface with satisfactory proof of the defect and that the product was properly installed, maintained, and operated within the limits of rated and normal usage; (2) buyer obtains from Interface authorization to return the product; and (3) products claimed to be defective must be returned with transportation charges prepaid. Product will be returned to Buyer with transportation charges collect unless the item is found to be defective, in which case Interface will pay the return transportation charges.
3. The remedy set forth herein does not apply to damage to or defects in any product caused by the Buyer's misuse or neglect, nor does it apply to any product which has been repaired or disassembled, which in the sole judgement of Interface affects the performance of the product.
4. Interface makes no warranty concerning components not manufactured by it. However, in the event of the failure of any component or accessory not manufactured by Interface reasonable assistance will be given to Buyer in obtaining from the respective manufacturer whatever adjustment is reasonable based on the manufacturer's own warranty. Interface expressly disclaims any liability to its customers, dealers, and representatives, and to users of its products, and to any other person for special or consequential damages of any kind and from any cause whatsoever arising out of or in any way connected with the manufacture, sale, handling, repair, maintenance, or replacement arising out of or in anyway connected with the use of said products.
5. Representations and warranties made by any person, including dealers and representatives of Interface which are inconsistent or in conflict with the terms of this warranty (including but not limited to the limitations of the liability of Interface as set forth above), shall not be binding upon Interface unless reduced to writing and approved by an officer of Interface, Inc.

**THIS EXPRESS WARRANTY SUPERCEDES ANY AND ALL OTHER WARRANTIES, EXPRESSED OR IMPLIED, INCLUDING IMPLIED WARRANTY OF MERCHANTABILITY OR FITNESS FOR PARTICULAR PURPOSE.**

### **OBTAINING SERVICE UNDER WARRANTY**

Advance authorization is required before any product is returned to Interface. Prior to the return of any product, write or call the Repair Department at Interface advising them of: (1) a part number; (2) a serial number of the defective product; (3) a technical description of the defect including specific test data, written observations on the failure and specific corrective action required; (4) a no-charge purchase order number (so the product can be returned to sender correctly); and (5) ship and bill addresses. Non-verified problems or defects may be subject to an evaluation charge. Please return the original calibration data with the unit.

### **REPAIR WARRANTY**

All repairs of Interface products are warranted for a period of 90 days from date of shipment. This warranty applies only to those items which were found defective and repaired. It does not apply to products in which no defect was found and returned as is or merely recalibrated. Out of warranty products may not be capable of being repaired.

## DESCRIPTION

The Model 9860 is a TEDS IEEE 1451.4 compliant, enhanced performance, microprocessor-based digital indicator capable of interfacing directly to a low level strain gage load cell transducer. There are (3) calibration modes available to the user.

1. **CAL ON 1:** Manual entry of zero and calibration values using applied load, simulator, or RCAL.
2. **CAL ON 2:** Auto-calibration to a specific non-TEDS transducer, when the MAXIMUM FORCE and MAXIMUM ELECTRICAL values, of that specific transducer are known.
3. **TEDS:** Auto calibration when connected to a TEDS, template #33 configured transducer, with a one-wire DS2344 or equivalent interface. The retrieved MAXIMUM FORCE value is available for review in the menu parameter, FS, fullscale, as a check of the interface.

An internal, high gain, fully-differential amplifier and a 16-bit analog-to-digital converter combine to accurately digitize the input signal. The analog input is digitally filtered, to user selected sample size and filter window (band), allowing optimization for specific operating conditions, trading off depth of filtering and step change tracking. Self-calibrating +/- 10Vdc and 4-20mA analog output signals are standard. A RS232 interface provides facilities to communicate, command, query operating modes, parameters and to continuously read data.

A TEDS status indicator provides the information on the TEDS configuration of the input. See table for TEDS indicator description.

A 5Vdc@ 60mA or 10Vdc@120mA, short circuit protected, transducer excitation supply is also provided.

A front panel RCAL switch provides a convenient calibration feature. TARE and CALIBRATION are easily performed via front panel pushbuttons.

## SPECIFICATIONS

Excitation voltage: 5 or 10Vdc, internal jumper selectable  
Excitation current: 60mA @ 5Vdc, 120mA @ 10Vdc  
Input amp gain: 100 or 200  
Input impedance: 1000 megohm (min)  
Input bias current: 10nA (max)  
Zero tempco: +/-1uV/degC (typ)  
Gain tempco: +/-20ppm/degC (typ)  
CMRR: 120dB @ 50-60Hz  
Signal input range: +/-25mV at Input amp gain = 200  
+/-50mV at Input amp gain = 100  
Max internal counts: +/-32,768 over signal input range  
Max display range: +/-99,999  
Sensitivity: 0.8uV/internal count at input amp gain = 200  
Conversion rate: 120 samples/second  
Analog Filter: 2-pole, 1000Hz low pass  
Digital Filter: Moving average filter with user selectable number of averages and filter window  
Nonlinearity: +/-0.01% +/-1 internal count  
Step Response: 25ms (without digital filtering)  
Analog Outputs: +/-10Vdc and 4-20mA (self-calibrating)  
Serial Output: Bi-directional RS232 with internally selectable baud rates  
Operating range: -10 to 50 degC  
Input Power: 100 to 250Vac, 50/60 Hz universal switching power supply  
Pkg dimensions: 3.78W x 1.89H x 5.13D

# INSTALLATION AND WIRING

## INSTALLATION

The Model 9860 enclosure is designated for panel mounting in a 1/8 DIN cutout. The cutout dimensions are shown below.

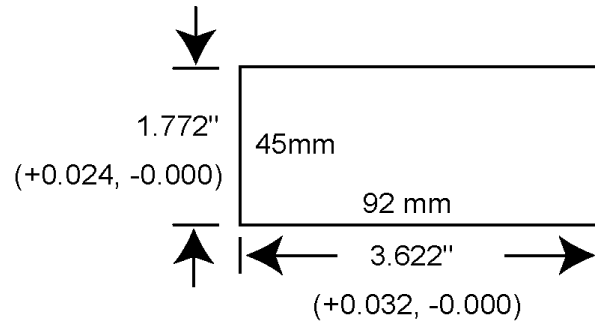

To panel mount the 9860, perform the following steps.

1. Rotate the four pawl screws (outside screws in each corner) several turns counter-clockwise to retract the pawls. Make sure the pawls retract enough to clear the back of the mounting panel. The pawls may be retracted to accommodate panel thicknesses up to 0.25 inches (6.35mm).
2. Insert the instrument into the panel cutout.
3. Position the pawls so that their elongated dimension overlaps the panel cutout, then tighten the screws. Do not over-tighten.
4. Installation complete.

## WIRING

Reference Figures 3 and 4 for TRANSDUCER and I/O wiring information. Power is applied with a 3-prong AC power cord. The instrument is protected by a 250V, 250mA slow acting 5mm fuse. The fuse holder is an integral part of the input power connector. A spare fuse is provided in the fuse holder. Internal solder jumpers are provided to allow 115Vac or 230Vac operation (Reference Figure 6 on page 5).

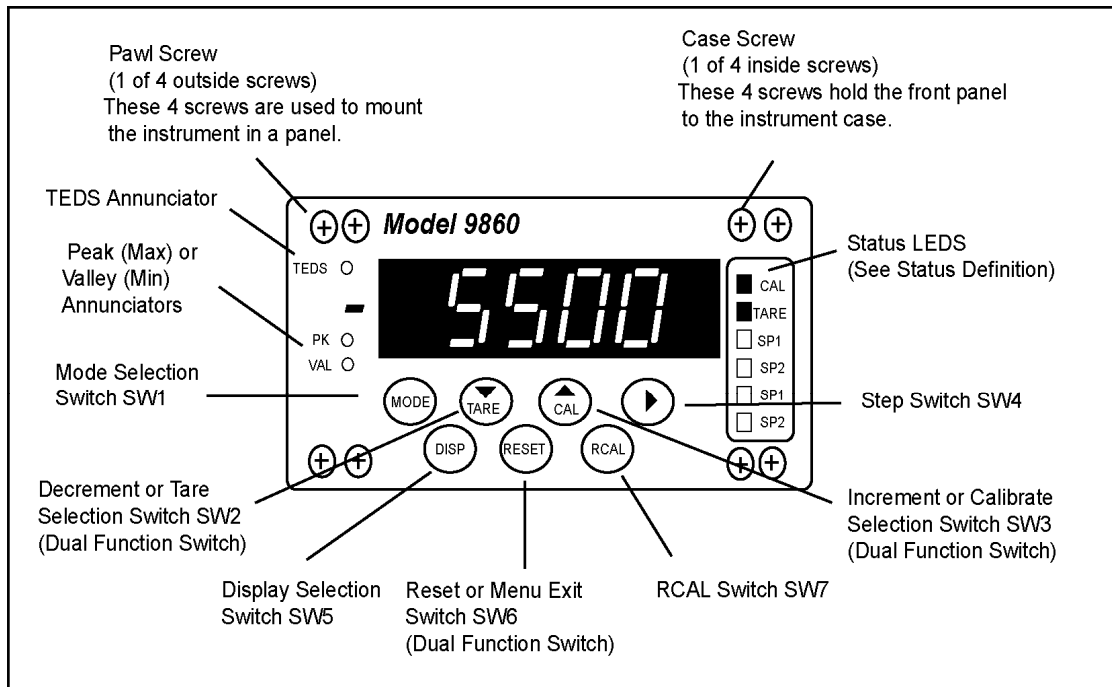

Figure 1. Model 9860 Front Panel View

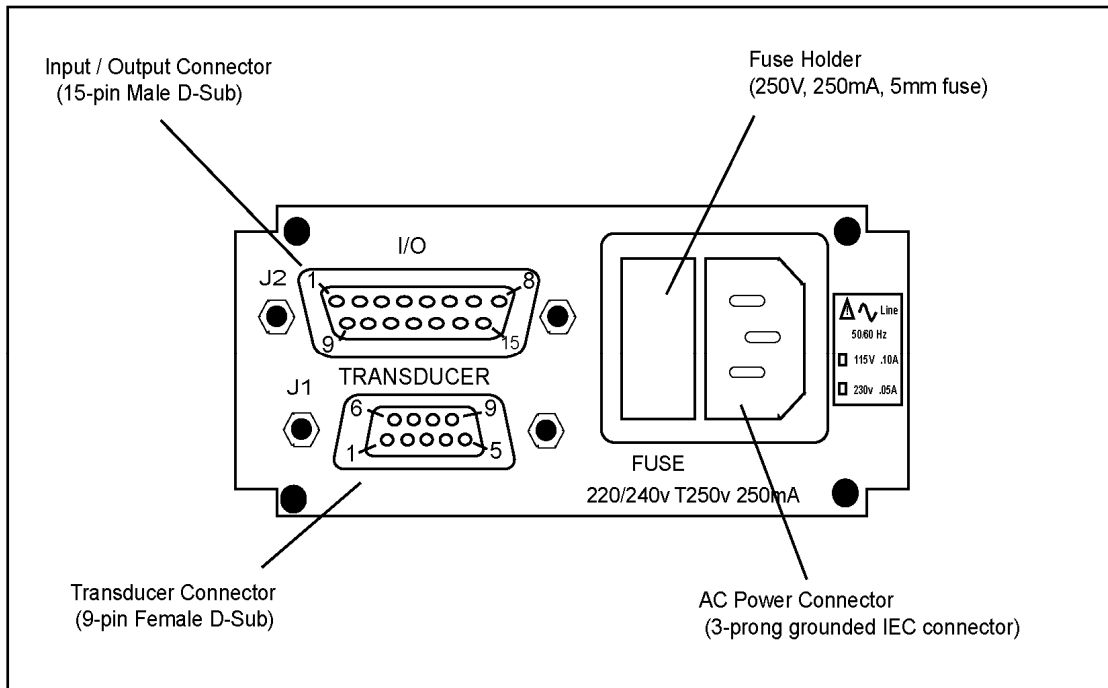

Figure 2. Model 9860 Rear Panel View

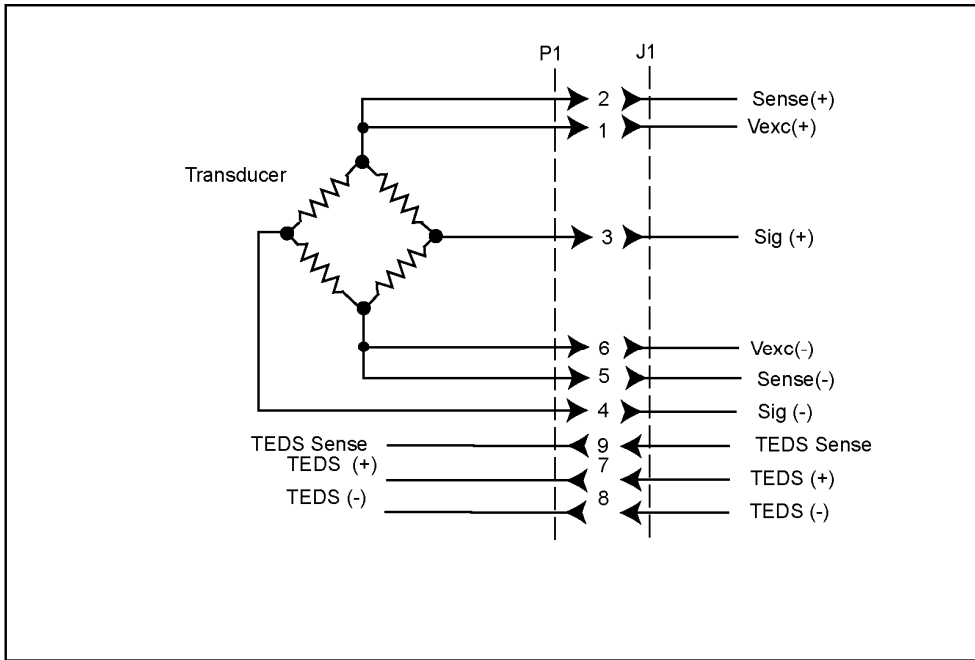

Figure 3. Transducer Wiring

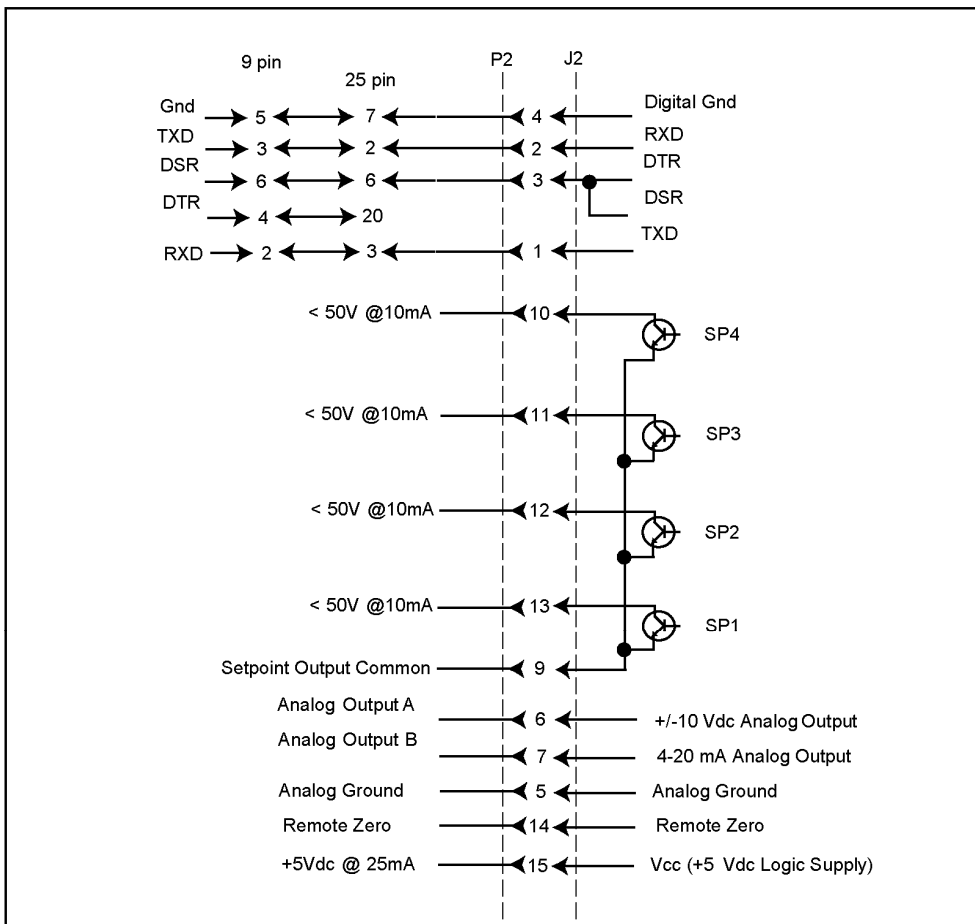

Figure 4. I/O Wiring

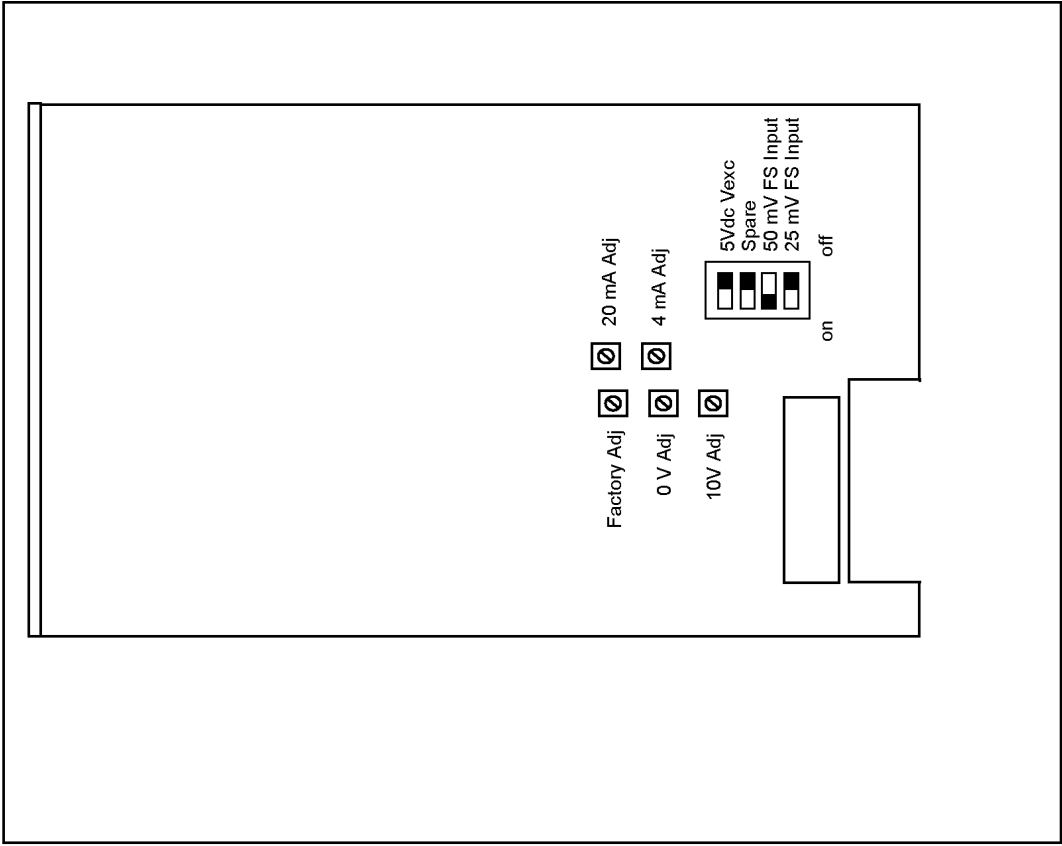

Figure 5. Location of Gain / Vexc Select Switches and Analog Output Adjustment Potentiometers

## Open Collector Outputs

The Interface model 9860 load cell indicator is equipped with open collector set point outputs. Open collector outputs work somewhat like relay contacts except that they only allow current to flow one way. Since these outputs are floating, they can be used with any voltage source up to 50 VDC. In this way you can match the output voltage level of the 9860 to any external equipment input be it 2.5 VDC or 48 VDC.

Open collector outputs do not produce any voltage on their own

NPN open collector outputs are “pull” type outputs, meaning they are only able to pull the output towards a common ground. The pull up resistor is necessary to reassert the high level when the transistor is turned off.

You will notice that since open collector outputs sink current they seem to work in reverse. The output transistor turns on when the set point LED on the front panel is lit. Using the standard configuration shown in figure 1, the set point output will be +5 VDC when the set point LED is off and 0 VDC when the LED is on.

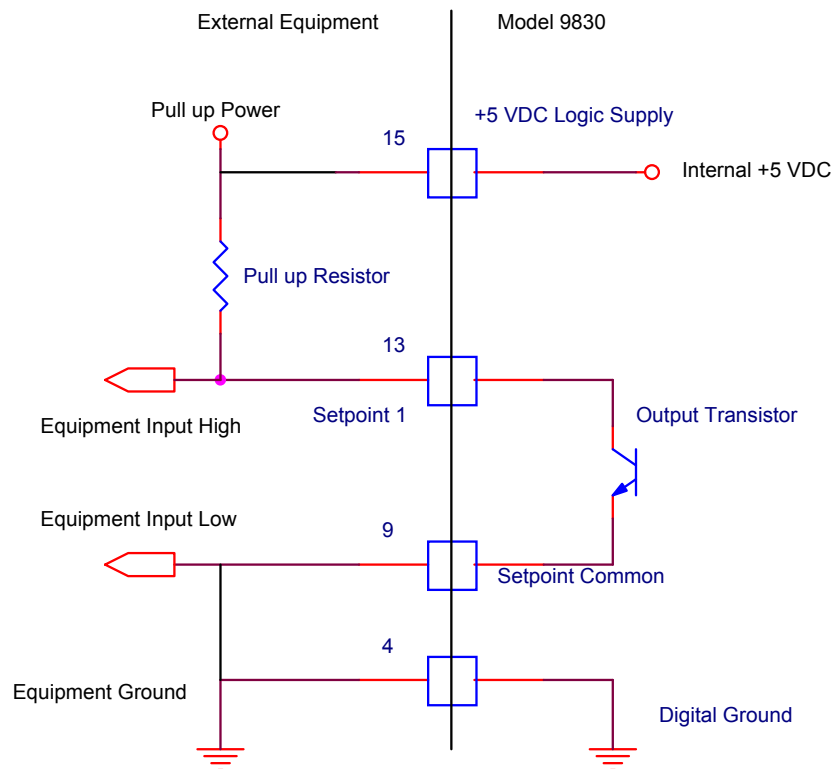

**Figure 1**

Figure 1 shows a typical installation with the dotted line from pin 15 showing the use of the 9860 internal +5 volt supply as the pull up power supply. The pull-up resistor must be chosen to limit the current through to < 10 mA (a value between 2.5 K $\Omega$  and 5 K $\Omega$  should be fine). If the internal +5 VDC supply is used, the current draw of all 4 set point outputs must be lower than 25 mA. Note that the model 9860 pin 4 digital ground must be connected to a ground referenced to the user's equipment input, while pin 9, the output common, although usually connected to ground, can be connected to any voltage that is more negative than that of pin 15.

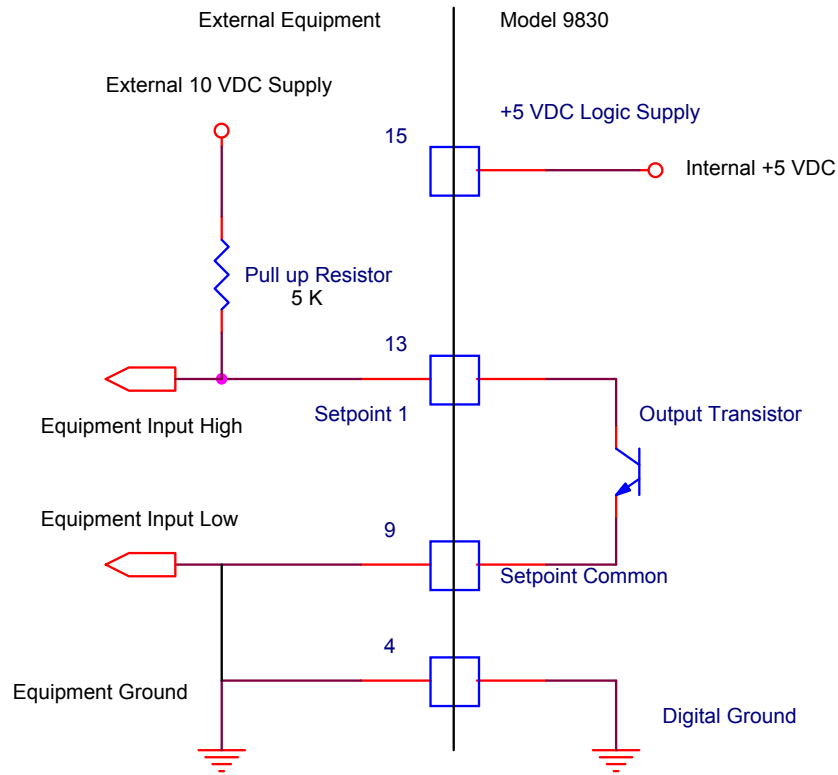
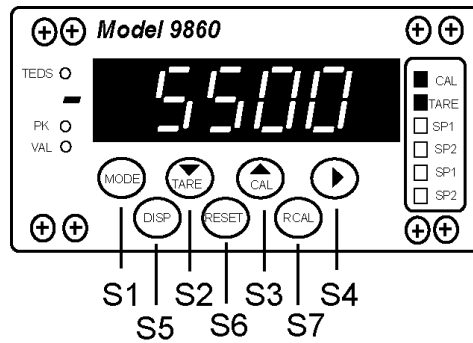

**Figure 2**

When using an external power supply as in figure 2 to provide power to the set point outputs, the value of the pull-up resistor in ohms should be between  $\text{SUPPLY VOLTAGE} / .01$  as the lowest value and  $\text{SUPPLY VOLTAGE} / .001$  as the highest.

# SWITCH AND FUNCTION DEFINITIONS

## SWITCH DEFINITIONS



### Mode Selection Switch (S1)

S1 is used to cycle through the various programmable functions of the 9860. The sequence is as follows. The designators, in ( ), identify text that will be displayed. The settable values are shown in { }.

#### Factory Default Settings

Full Scale CAL Switch Disabled (CAL) {OFF, On 1, On 2}	{OFF}
Least Significant Digit (Lsd) {ON, ZER0}	{ON}
Decimal Point (dP) {x.xxxx, xx.xxx, xxx.xx, xxxx.x, xxxxx}	{xxxxx}
Filter Value (FILtEr) {00 to 99}	{95}
FilterWindow Value (bAnd) {001 to 999}	{010}
Calibration Number (CAL) {00001 to +/-99999}	{10000}
Scalefactor (SCALE) {0.00000 to 9.99999}	{4.00000}
Full Scale Number (FS) {00001 to +/-99999}	{10000}
Setpoint 1 to Monitor (SP -) {Instantaneous, Peak, Valley, Peak-Valley}	{Instantaneous}
Setpoint 1 to be (SP HI) {High Setpoint} or (SP LO) {Low Setpoint}	{High Setpoint}
Set Setpoint 1 Value (Set SP) {00000 to +/-99999}	{99999}
Setpoint 2 to Monitor (SP -) {Instantaneous, Peak, Valley, Peak-Valley}	{Instantaneous}
Setpoint 2 to be (SP HI) {High Setpoint} or (SP LO) {Low Setpoint}	{High Setpoint}
Set Setpoint 2 Value (Set SP) {00000 to +/-99999}	{99999}
Setpoint 3 to Monitor (SP -) {Instantaneous, Peak, Valley, Peak-Valley}	{Instantaneous}
Setpoint 3 to be (SP HI) {High Setpoint} or (SP LO) {Low Setpoint}	{High Setpoint}
Set Setpoint 3 Value (Set SP) {00000 to +/-99999}	{99999}
Setpoint 4 to Monitor (SP -) {Instantaneous, Peak, Valley, Peak-Valley}	{Instantaneous}
Setpoint 4 to be (SP HI) {High Setpoint} or (SP LO) {Low Setpoint}	{High Setpoint}
Set Setpoint 4 Value (Set SP) {00000 to +/-99999}	{99999}
Hysteresis for Low Setpoints (HL) {000 to 200}	{000}
Hysteresis for High Setpoints (HH) {000 to 200}	{000}
Baud rate (bAud) {9600, 19200,38400,57600,115200}	{115200}
Depress Mode Again to Exit (run)	

While in the Mode Selection sequence, the indicator is no longer monitoring the input signal. To exit, depress RESET, S6, once.

### Decrement or Tare Switch (S2)

This switch serves two functions, depending on the present status of S1. If the meter is in the Mode Selection sequence, this switch decrements the flashing digit.

If the meter is in its normal operating mode, S2 becomes the TARE switch. Depressing S2 will automatically zero the readout, illuminate the TARE LED and zero the analog output. Depressing and holding S2 depressed for approximately 3 seconds will UNTARE the readout and extinguish the TARE LED. TARING is accomplished by storing the reading prior to TARING and subtracting this value from all subsequent readings.

## SWITCH DEFINITIONS (CONT)

### Increment or Cal Switch (S3)

This switch serves two functions, depending on the present status of S1. If the instrument is in the Mode Selection sequence, this switch has (2) functions.

1. In the CAL selection mode, it selects the calibration mode: OFF, ON 1 or ON 2.
2. In the parameter update mode, it will increment the flashing digit or toggle status.

If the instrument is in its operating mode, S3 has no function.

*Caution: In the CAL1 sequence, S3 is used to input zero and calibration values. Be sure to read the CALIBRATION INSTRUCTIONS before using this switch.*

### Step Switch (S4)

When the instrument is in the Mode Selection sequence, this switch allows the user to cycle through the digits. Used in conjunction with S2 and S3, it allows rapid updating of the Set Point, Hysteresis and Cal values.

### Display Switch (S5)

This switch cycles the readout to display:

	Annunciator(s) Illuminated:
Peak-Valley	Peak and Valley
Peak	Peak
Valley	Valley
Instantaneous Value	None

While in the Peak-Valley, Peak or Valley readout mode, the RESET switch (S6) resets the readout to the instantaneous value. In the Peak-Valley readout mode, (S6) resets both Peak and Valley readouts to the instantaneous value.

### Reset or Exit Switch (S6)

This switch also serves two functions, depending on the present status of S1. If the instrument is in the Mode Selection sequence, this switch is used to Exit this sequence and return to the normal display mode. Any selections made during the Mode Selection sequence, prior to that selected just before exiting, will be saved and remembered in non-volatile memory.

If the instrument is in the normal display mode this switch will reset the Peak, Valley and Peak-Valley readings to the instantaneous value.

### RCAL Switch (S7)

This switch activates a reed relay, which places a fixed resistor across Sig(-) and Vexc(-) for a positive RCAL reading, or across Sig(+) and Vexc(-) for a negative RCAL reading. Solder jumpers 3 and 4 determine which RCAL reading is generated (Reference Figure 6).

## FUNCTION DEFINITIONS

### Filter Value (FILtEr) {00 to 99}

The 9860 uses a filter based on a digital averaging technique where N samples are arithmetically averaged.

Subsequent averages subtract the oldest reading and adds the newest reading. The number of readings is equal to the value of (FILtEr).

Higher (FILtEr) values produce stronger filtering. Maximum filtering = 99.

### Filter Band (bAnd) {001 to 999}

To permit a heavy filter and still have fast response to a step input change, the filter operates only inside a stable band. If two consecutive conversions have a difference greater than the **bAnd value**, the filter automatically sets (FILtEr) =00, permitting maximum response. When the difference is again within the **bAnd value**, the filter returns to the selected (FILtEr) value. *The factory default is (bAnd) = 10.*

### Decimal Point (dP) {x.xxxx, xx.xxx, xxx.xx, xxxx.x, xxxxx}

dP allows selection of decimal point locations for display. The locations selectable are shown in { } above. The Increment and Decrement switches are used to shift decimal places.

### Calibration Number (CAL) {00001 to 99,999}

In the **CAL ON 1** mode, the (CAL) is equal to the desired reading corresponding to the calibration load, whether the load is actual, simulated or from RCAL. The number is entered prior to performing the calibration. A Full Scale Number must also be entered to scale the ANALOG outputs. See ANALOG OUTPUTS for a detailed description.

In the **CAL ON 2** mode, (CAL) is equal to the FULL SCALE value of the transducer. The full scale value will be automatically set to the Calibration Number.

In the **TEDS** mode, the (CAL) value is automatically set, by the instrument, to the (FS) value read from the transducer. See CALIBRATION PROCEDURE for more details.

### Scale

In the **ON 2** mode, the SCALE value is equal to the transducer MAXIMUM OUTPUT value, in mV/V. It is used to perform auto calibration. SCALE is only changeable in the ON2 mode.

## FUNCTION DEFINITIONS (CONT)

### Full Scale Number (FS) {00001 to +/-99999}

In the **ON 1/OFF** mode, the (FS) represents the value at which the ANALOG output is at full value. (FS) is user entered.

In the **ON 2** mode, the (FS) value is equal to the user entered CAL value. (FS) is automatically updated when the CAL value is updated. It cannot be altered by the user.

In the **TEDS** mode, (FS) is used to indicate the full scale value of a TEDS transducer. (FS) cannot be changed in this mode.

### Setpoint 1 to Monitor (SP1 -) {SP1 -, SP1 , SP1 , SP1 }

This function allows Setpoint 1 to monitor the instantaneous, peak, valley or peak minus valley displays. The Increment or Decrement switches are used to cycle through the various displays. To signify which display is being monitored, the least significant 7-segment display will be illuminated as shown below.

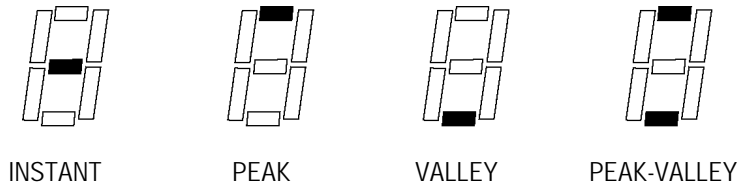

### Setpoint 1 to be (SP1 HI) {SP1 HI, SP1 LO}

This allows Setpoint 1 to be a High or Low Setpoint. The Increment or Decrement switches are used to cycle through the HI or LO selection.

A High Setpoint is disabled when the compared value is less than the Setpoint value. The High Setpoint is enabled when the compared value is equal to or greater than the Setpoint value.

A Low Setpoint is disabled when the compared value is greater than the Setpoint value. The Low Setpoint turns on when the compared value is equal to or less than the Setpoint value.

### Set Setpoint 1 Value (SEt SP) {00000 to +/-99,999}

Setpoint 1 can be set for any value from 00000 to +/-99,999. This value along with the previous selection of SP HI or SP LO determines when the optically isolated open-collector output transistors are activated and the SP1 annunciator illuminated.

**For Setpoints 2, 3 and 4, refer to Setpoint 1 setup, shown above.**

### Hysteresis Low (HL) {00 to 99}

HL is the hysteresis value for all Setpoints set to SP LO. HL determines the value the displayed reading must exceed the Setpoint value by, before deactivating their respective open-collector output(s).

### Hysteresis High (HH) {00 to 99}

HH is the hysteresis value for all Setpoints set to SP HI. HH determines the value the displayed reading must get below the Setpoint value by, before deactivating their respective open-collector output(s).

# OPERATING INSTRUCTIONS

## TURN-ON INSTRUCTIONS

Reference Figures 3 and 4 for proper input and output signal wiring.

1. Apply power to the instrument.
2. Verify the instrument readout momentarily displays a **relx.xr** value.

## PROGRAM INSTRUCTIONS

(4) front panel switches (S1, S2, S3 and S4) allow the user to program Cal Mode, LSD, Decimal Point (dP), Filter Value, Filter Window (bAnd), Calibration Number (CAL), Scale, Full Scale Number (FS), Setpoint to Monitor (SP-), Setpoint to be (SP HI), Setpoint Value (Set SP), Hysteresis Low (HL), Hysteresis High (HH) and Baud rate values.

To exit the MODE sequence without enabling a change, depress the RESET switch. All entries prior to RESET, not including the function active at RESET, will be updated.

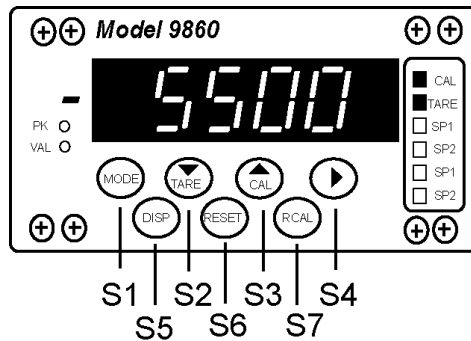

- 1) Depress MODE (S1) once.

The text **CodE** will be displayed. Depress the switches in the sequence shown.

S3 - S2 - S3

The text **CAL** will be displayed briefly, then **OFF** or **ON 2**, depending on the last calibration mode set.

The CAL function of the INCREMENT/CAL switch is disabled, to prevent inadvertent calibration.

Depressing the INCREMENT or DECREMENT switch will cycle the sequence **OFF**, **ON 1**, **ON 2**.

Refer to the CALIBRATION INSTRUCTIONS for details on the (3) calibration modes.

- 2) Depress MODE (S1) switch once.

The text **LSd** will be displayed momentarily, followed by **ON**. Depressing the INCREMENT or DECREMENT switch will cycle the sequence **ON**, **ZErO**. The feature allows the least digit to be active or set to 0.

- 3) Depress MODE (S1) switch once.

The text **dP** followed by the decimal point location will be displayed. Use S2 or S3 to locate the decimal point. To store the selected value in non-volatile memory, depress the MODE switch. To exit the MODE sequence without storing the new value in non-volatile memory depress the RESET switch. Reference Decimal Point in the Function Definitions section for more information.

- 4) Depress MODE (S1) switch once.

The text **FILtEr** followed by the current setting of the Filter value will be displayed. Use S2, S3, and/or S4 to change the value. To store the selected value in non-volatile memory, depress the MODE switch. To exit the MODE sequence, without storing the new value in non-volatile memory, depress the RESET switch. Reference Filter Value in the Function Definitions section for more information.

## PROGRAM INSTRUCTIONS (CONT)

**5)** Depress MODE (S1) switch once.

The text **bAnd** followed by the current setting of the Filter Window will be displayed. Use S2, S3 and/or S4 to change the current value. To store the selected value in non-volatile memory, depress the MODE switch. To exit the MODE sequence, without storing the new value in non-volatile memory, depress the RESET switch. Reference Filter Window in the Function Definitions section for more information.

**6)** Depress MODE (S1) switch once.

The text **CAL** followed by the current value of the Calibration number will be displayed. To store the selected value in non-volatile memory, depress the MODE switch. To exit the MODE sequence, without storing the new value in non-volatile memory depress the RESET switch. Reference Calibration Number in the Function Definitions section for more information.

**7)** Depress MODE (S1) switch once.

The text **SCALE** followed by the current value of the Scale Number will be displayed. Use S2, S3 and/or S4 to change the current value. Care should be given to ensure the correct positive or negative sign is input. To store the selected value in non-volatile memory, depress the MODE switch. To exit the MODE sequence, without storing the new value in non-volatile memory depress the RESET switch. Reference Scale in the Function Definitions section for more information.

**8)** Depress Mode (S1) switch once.

The text **FS** followed by the current value of the Full Scale Number will be displayed. This value is the Maximum value for the present or last connected TEDs enabled transducer, and cannot be altered. It is for reference only. To exit the MODE sequence, depress the RESET switch. Reference FS in the Function Definitions section for more information.

**9)** Depress MODE (S1) switch once.

The text **SP1** - will be displayed. Use S2 and S3 to change the parameter SP1 is to monitor. To store the selected parameter in non-volatile memory, depress the MODE switch. To exit the MODE sequence without storing the new parameter in non-volatile memory depress the RESET switch. Reference SP1 to Monitor in the Function Definitions section for more information.

**10)** Depress MODE (S1) switch once.

The text **SP1 HI** or **SP1 LO** will be displayed. Depressing S2 or S3 alternates SP1 HI and SP1 LO. To store the selected parameter in non-volatile memory, depress the MODE switch. To exit the MODE sequence, without storing the new parameter in non-volatile memory depress the RESET switch. Reference SP1 HI in the Function Definitions section for more information.

**11)** Depress MODE (S1) switch once.

The text **SEt SP** will be displayed momentarily, followed by the current value of Setpoint 1. Use S2, S3 and/or S4 to set a new value. Care should be given to ensure the correct positive or negative sign is input. To store the selected parameter in non-volatile memory, depress the MODE switch. To exit the MODE sequence, without storing the new parameter in non-volatile memory, depress the RESET switch. Reference Set SP in the Function Definitions section for more information.

**12)** Depress MODE (S1) switch once.

The text **SP2** - will be displayed. Reference SP1 - setup instructions on to set SP2 -.

## PROGRAM INSTRUCTIONS (CONT)

**13)** Depress MODE (S1) switch once.

The text **SP2 HI** or **SP2 LO** will be displayed. Reference SP1 HI setup instructions to set SP2 HI or SP2 LO.

**14)** Depress MODE (S1) switch once.

The text **SEt SP** will be displayed momentarily, followed by the current value of Setpoint2. Reference SET SP setup instructions above to set a new value for Setpoint 2.

**15)** Depress MODE (S1) switch once.

The text **SEt SP3** will be displayed. Reference SP1 - setup instructions to set SP3 -.

**16)** Depress MODE (S1) switch once.

The text **SP3 HI** or **SP3 LO** will be displayed. Reference SP1 HI setup instructions to set SP3 HI or SP3 LO.

**17)** Depress MODE (S1) switch once.

The text **SEt SP** Will be displayed momentarily, followed by the current value of Setpoint 3. Reference SET SP setup instructions above to set a new value for Setpoint 3.

**18)** Depress MODE (S1) switch once.

The text **SP4 -** will be displayed. Reference SP1 - setup instructions to set SP4 HI or SP4 LO.

**19)** Depress MODE (S1) switch Once.

The text **SP4 HI** or **SP4 LO** will be displayed. Reference SP1 HI setup instructions to set SP4 HI or SP4 LO.

**20)** Depress MODE (S1) switch once.

The text **SEt SP** will be displayed momentarily, followed by the current value of Setpoint 4. Reference SET SP setup instructions above to set a new value for Setpoint 4.

**21)** Depress MODE (S1) switch once.

The text **HL** will be displayed momentarily, followed by the current value of Hysteresis Low. Use S2, S3 and S4 to set a new value for HL. To store the new value of HL in non-volatile memory, depress the MODE switch. To exit the MODE sequence, without storing the new value, depress the RESET switch.

**22)** Depress MODE (S1) switch once.

The text **HH** will be displayed momentarily, followed by the current value of Hysteresis High. Use S2, S3 and S4 to set a new value for HH. To store the new value of HH in non-volatile memory, depress the MODE switch. To exit the MODE sequence, without storing the new value, depress the RESET switch.

**23)** Depress MODE (S1) switch once.

The text **bAud** will be displayed momentarily, followed by the current value of RS232 baud rate. Use S2 or S3 to set a new value for bAud. To store the new value of bAud in non-volatile memory, depress MODE switch. To exit the MODE sequence, without storing the new value, depress the RESET switch.

**24)** Depress MODE (S1) switch once.

The text **run** will be displayed. Following a short delay, the instrument will return to displaying the **SEL** input.

## TEDS INDICATOR AND BLINK CONFIGURATIONS

The following TABLE describes the functionality of the red **TEDS** led. The presence of a TEDS enabled transducer is indicated by a ground on P1-9. See figure 3. The led is **ON** when a combination of TEDS Sense is grounded and/or TEDS ROM is detected. The particular combination is indicated by the led activity. If a TEDS Sense ground and valid TEDS ROM data are detected, the led is **ON** steady. If a TEDS Sense ground is detected and valid TEDS ROM is not detected, the led blinks **FAST**. If a TEDS Sense ground is not detected and valid TEDS ROM is detected, the led blinks **SLOW**. A blink condition indicates a problematic situation.

If both a TEDS Sense ground and valid a TEDS ROM are not detected, the led is **OFF**. The instrument is in either the **ON 1/OFF** or the **ON 2** calibration mode.

TEDS SWITCH	ROM DETECTED	TEDS LED	CAL MODE	BLINK STATE
NO	NO	OFF	OFF	NONE
NO	NO	OFF	ON 1	NONE
NO	NO	OFF	ON 2	NONE
NO	YES	ON	TEDS	SLOW
YES	NO	ON	TEDS	FAST
YES	YES	ON	TEDS	NONE

# CALIBRATION INSTRUCTIONS

The Model 9860 provides three (3) calibration modes, including an **OFF** state. In the **OFF** state, the **ON 1** manual entry function is disabled.

## 1) ON 1:

**Manual calibration when connecting to a non-TEDS sense enabled transducer, and unknown MAXIMUM ELECTRICAL VALUE, in mV/V. This mode is also used with RCAL facility.**

In the Manual mode, the calibration is established by entering zero and fullscale points, using an external reference. The calibration sequence is as follows:

1. Cycle the power.
2. Ensure that the unit is in the untared and uncalibrated mode.
3. Through the MENU sequence
  - a. Set the calibration mode to **ON1**
  - b. Set **CAL** to the calibration value.
  - c. Set **FS** to the fullscale value.
4. Exit MENU.
5. Connect the calibration source.
6. Input zero volts.
7. Depress the **CAL** button once.
8. Apply an analog voltage representing the **CAL** value, then depress the **CAL** button.
  - a. The **CAL** value will be displayed.
  - b. The calibration mode defaults to **OFF**, preventing inadvertent calibration.
9. Connect transducer.

The **CAL** and **FS** values are stored in non-volatile memory. The unit remains in the **ON 1/OFF** mode, until a calibration mode change is made. On power cycling, if the unit was in the **ON 1/OFF** mode, it will restart in the **ON 1/OFF** mode, unless it detects a TEDS transducer, in which case it defaults to the auto calibration

**Caution:** If the **CAL** or **FS** value changed, through the MENU or RS232 command, the instrument must be recalibrated.

## 2) ON 2:

**Auto calibration when connecting to a non-TEDS transducer, with known MAXIMUM FORCE and MAXIMUM ELECTRICAL values.**

In the non TEDS auto mode, the calibration is established using preset values. The calibration sequence is as follows:

1. Cycle Power.
2. Through the MENU sequence
  - a. Set the calibration mode to **ON 2**.
  - b. Set **CAL** value to the transducer data sheet MAXIMUM FORCE value. The **FS** value will auto set to the **CAL** value
3. Connect the transducer.

The **CAL**, **FS** and **Scale** values are stored in non-volatile memory. The unit remains in the **ON 2** mode, until a calibration mode change is made. On power cycling, if the unit was in the **ON 2** mode, it will restart in the **ON 2** mode, unless it detects a TEDS transducer, in which case it defaults to the auto calibration **TEDS** mode.

## 3) TEDS:

**Auto calibration when connecting to a TEDS, template #33 configured transducer, with TEDS sensing pin.**

In the **TEDS AUTO MODE**, the unit self calibrates to the **MAXIMUM FORCE** and **MAXIMUM ELECTRICAL VALUE** values. The **MAXIMUM FORCE** value is displayed as **FS** and **CAL**, in MENU.

The calibration sequence is as follows:

1. Connect the transducer.
2. Apply power.

The **TEDS parameters** are stored in non-volatile memory. When the TEDS transducer is disconnected and reconnected or a different TEDS transducer, with sensing pin, is connected, the unit automatically self calibrates, without the need for power recycling.

The **TEDS LED** indicates the state of the TEDS connection. See **TEDS INDICATOR AND BLINK CONFIGURATIONS** for a detail description.

## EXCITATION SUPPLY

A 5Vdc@ 60mA or 10Vdc@ 120mA, short circuit protected, transducer excitation supply is provided. The output voltage is switch selectable, by programming an internal selector switch.

The connection to the transducer is shown in the following figure. The SENSOR connections can be made at the 9860, if cabling is not convenient. Connecting at the TRANSDUCER provides a more stable excitation voltage at the TRANSDUCER.

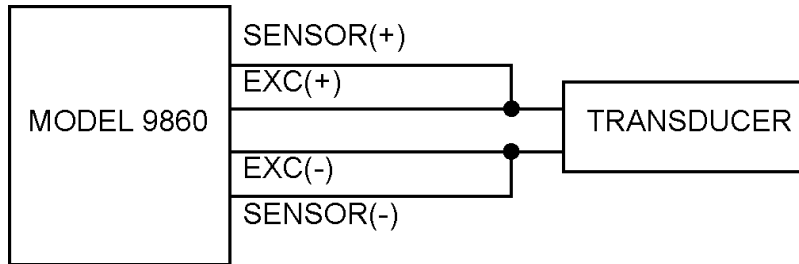

The EXC output is short circuit protected from shorts to ground. When a short to ground is detected, the output current is reduced to prevent damage. In most cases, removing the short will cause the output to recover. If removing the short fails to cause recovery, recycle the AC line power.

## ANALOG OUTPUTS

The 9860 provides self-calibrating 10Vdc and 4-20mA analog output signals. The maximum output of 10 volts or 20 mA corresponds to the FULLSCALE value. Both the 10V output and the 4-20 mA outputs are automatically scaled by (FS). (FS) = the display value that corresponds to the full scale spans of the outputs, either 10V or 20 mA. The ANALOG output is proportional to the input.

Examples:

- 1) A 9860 reads a TEDS capable transducer with a maximum capacity of 10,000 lb. FS will indicate 10000. The actual load is 4000 lb. The voltage output is  $+(4000/10000) \times 10 = +4$  V and  $+(4000/10000) \times 16 + 4 = 10.4$  mA.
- 2) A 9860 is in the ON 1/OFF mode. The CAL and FS values are 10000 lb and 20000 lb, respectively. The actual load is 50000 lb. The voltage output is  $+(5000/20000) \times 10 = +2.5$  V and  $+(5000/20000) \times 16 + 4 = 8.0$  mA.
- 3) A 9860 is in the ON 2 mode. The CAL and FS values are 15000 lb. The actual load is 9000 lb. The voltage output is  $+(9000/15000) \times 10 = +6.0$  V and  $+(9000/15000) \times 16 + 4 = 13.6$  mA.

The TARE function operates on the analog output the same as it does on the digital display. The analog output is continuously amplified analog signal with digitally controlled gain. The polarity of the analog output is always the same as the signal input. However, the 4-20 mA output is unipolar and must always be used with a positive input signal.

# SERIAL RS232 COMMUNICATIONS

## General Information

See Figure 4 on page 4 for RS232 connections and wiring information.

The RS232 port is always active. The data is ASCII and is transmitted in the following format:

- One Start Bit;
- Eight Data Bits;
- No Parity Bit;
- One Stop Bit;

Baud rate is set through the menu sequence or RS232 command. Available baud rates: 9600, 19200, 38400, 57600, 115200.

Transmissions to and from the Model 9860 is defined in the following Tables:

<CR> denotes ENTER

XON and XOFF are used to control transmission of a continuous data stream

INPUT, MAX, MIN or MAX-MIN, as being displayed, will be transmitted.

The data being transmitted can be changed from the front panel SEL switch or by RS232 command.

During data transmission, most COMMANDS and QUERYs are functional.

RESET, will function as the front panel switch.

The FILTER VALUE and FILTER BAND can be updated and will immediately be implemented.

TARE and UNTARE are active.

DECIMAL POINT can be altered. **CAUTION: changing the DECIMAL POINT will cause the MAX-MIN value to be in error. The MAX-MIN value must be RESET after the DECIMAL POINT change.**

The LSD can be turned ON and Off.

The HYSTERESIS values can be changed.

SETPOINT parameters can be modified.

## SERIAL RS232 COMMUNICATIONS (CONT)

QUERY/COMMAND	RESPONSE	NOTES
BR<n><CR>	Baud Rate Selection	n= 9600, 19200, 38400, 57600 or 115200
CV<CR>	Cal Value	Full 6 digits
CV<nnnnnn><CR>	Cal Value	Full 6 digits
CS<CR>	Cal mV/V for psuedo TEDS	Use 0.00nnnnn or n.nnnnE-03 format
CS<nn.nnnn><CR>	CAL Mv/v for psuedo TEDS	Use 0.00nnnnn or n.nnnnE-03 format
DP<CR>	Decimal Point Value	0 <=n <=5
DP<n><CR>	Decimal Point Value	0 <=n <=5
FB<CR>	Filter Band Value	Full 3 digits
FB<nn><CR>	Filter Band Value	Full 3 digits
FS<CR>	Fullscale Value	Full 6 digits
FS<nnnnnn><CR>	Fullscale Value	Full 6 digits
FV<CR>	Filter Value	00 <=nn <=99
FV<nn><CR>	Filter Value	00 <=nn <=99
HH<CR>	Hysteresis High Value	00 <=nn <=99
HH<nn><CR>	Hysteresis High Value	00 <=nn <=99
HL <CR>	Hysteresis Low Value	00 <=nn <=99
HL<nn><CR>	Hysteresis Low Value	00 <=nn <=99
IF<CR>	Instrument FS Value	adc output value with no-TEDs at scaling analog input
IS<CR>	Instrument Scale Value	scaling analog input voltage
IZ<CR>	Instrument Zero Value	adc output value with no-TEDs at zero analog input
LD<CR>	Least Display Digit ON-OFF	1=OFF; 0 = ON
LD<n><CR>	Least Display Digit ON-OFF	1=OFF; 0 = ON
PD<CR<	Parameter MAX - MIN value	MAX - MIN value
PDD<CR>	MAX - MIN	Display MAX - MIN value
PI<CR>	Parameter instant adc value	Present scaled adc value
PID<CR>	INSTANTANEOUS adc	Display INSTANTANEOUS adc value
PP<CR>	Parameter MAX value	Maximum scaled adc value
PPD<CR>	MAX	Display MAX value
PV<CR>	Parameter MIN value	Minimum scaled adc value
PVD<CR>	MIN	Display MIN value

## SERIAL RS232 COMMUNICATIONS (CONT)

QUERY/COMMAND	RESPONSE	NOTES
RS<CR>	Reset	Execute as RESET switch SF<CR>
Scalefactor	Value	Scalefactor in E format
SF<nn.nnnn><CR>	Scalefactor Value	Use 0.00nnnnn or n.nnnnE-03 format
SP1L<CR>	Setpoint1 HI or LO	0 = LOW; 1 = HIGH
SP1L<n><CR>	Setpoint1 HI or LO	0 = LOW; 1 = HIGH
SP1P<CR>	Setpoint1 Parameter	0 = adc; 1=max; 2=min; 3=max-min
SP1<n><CR>	Setpoint1 Parameter	0 = adc; 1=max; 2=min; 3=max-min
SP1V<CR>	Setpoint1 Value	Full 6 digits
SP1V<nnnnnn><CR>	Setpoint1 Value	Full 6 digits
SP2L<CR>	Setpoint2 HI or LO	0 = Low; 1 = HIGH
SP2L<n><CR>	Setpoint2 Hi or LO	0 = LOW; 1 = HIGH
SP2P<CR>	Setpoint2 Parameter	0 = adc; 1=max; 2=min; 3=max-min
SP2P<n><CR>	Setpoint2 Parameter	0 = adc; 1=max; 2=min; 3=max-min
SP2V<CR>	Setpoint2 Value	Full 6 digits
SP2V<nnnnnn><CR>	Setpoint2 Value	Full 6 digits
SP3L<CR>	Setpoint3 HI or LO	0 = LOW; 1 = HIGH
SP3L<n><CR>	Setpoint3 HI or LO	0 = LOW; 1 = HIGH
SP3P<CR>	Setpoint3 Parameter	0 = adc; 1=max; 2=min; 3=max-min
SP3P<n><CR>	Setpoint3 Parameter	0 = adc; 1=max; 2=min; 3=max-min
SP3V,CR>	Setpoint3 Value	Full 6 digits
SP3V<nnnnnn><CR>	Setpoint3 Value	Full 6 digits
SP4<CR>	Setpoint4 HI or LO	0 = LOW; 1 = HIGH
SP4L<n><CR>	Setpoint4 HI or LO	0 = LOW; 1 = HIGH
SP4P<CR>	Setpoint4 Parameter	0 = adc; 1=max; 2=min; 3=max-min
SP4P<n><CR>	Setpoint4 Parameter	0 = adc; 1=max; 2=min; 3=max-min
SP4V<CR>	Setpoint4 Value	Full 6 digits
SP4V<nnnnnn><CR>	Setpoint4 Value	Full 6 digits
ZA<n><CR>	TARE or UNTARE	0/1 = UNTARE/TARE; execute as TARE switch
ZA<CR>	Tare Status	0/1 = UNTARE/TARE; execute as TARE switch
[<CTRL>S],CR>	XOFF	Ends transmission of data

# MENU SEQUENCE

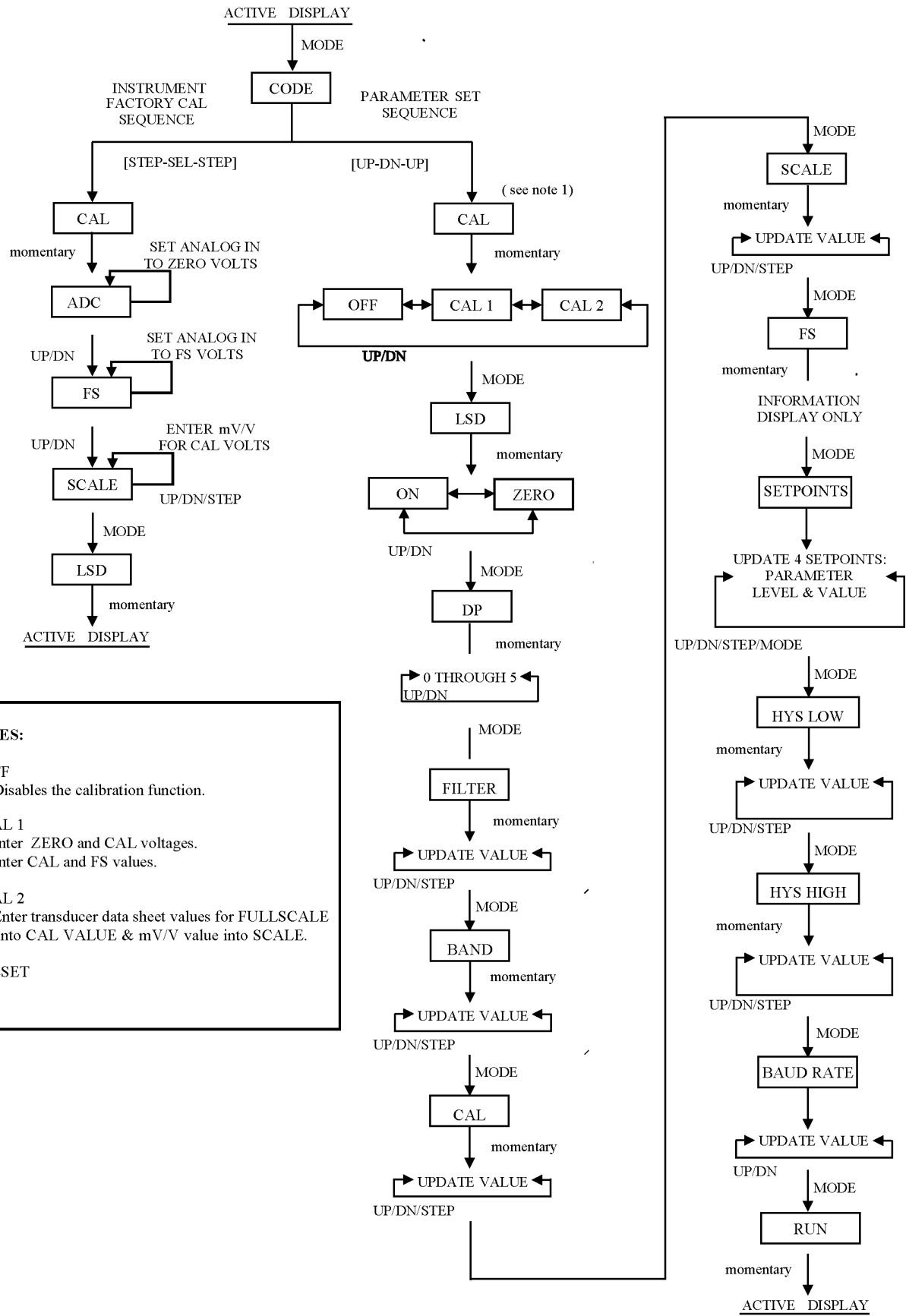

**NOTES:**

1. OFF  
Disables the calibration function.

CAL 1  
Enter ZERO and CAL voltages.  
Enter CAL and FS values.

CAL 2  
Enter transducer data sheet values for FULLSCALE into CAL VALUE & mV/V value into SCALE.

2. RESET