

## Application Note

### 9830, 9834, 9860 Open Collector Outputs

The Interface model 9830, 9834, and 9860 load cell indicators are equipped with open collector set point outputs. Open collector outputs work somewhat like relay contacts except that they only allow current to flow one way. Since these outputs are floating, they can be used with any voltage source up to 50 VDC. In this way you can match the output voltage level of the 9830 set point to any external equipment.

Open collector outputs do not produce any voltage on their own. NPN open collector outputs are “pull” type outputs, meaning that they are only able to pull the output towards a common ground. The pull up resistor is necessary to reassert the high level when the transistor is turned off.

You will notice that when open collector outputs sink current they seem to work in reverse. The output transistor turns on when the set point LED on the front panel is lit. Using the standard configuration shown in Figure 1, the set point output will be +5 VDC when the set point LED is off and 0 VDC when the LED is on.

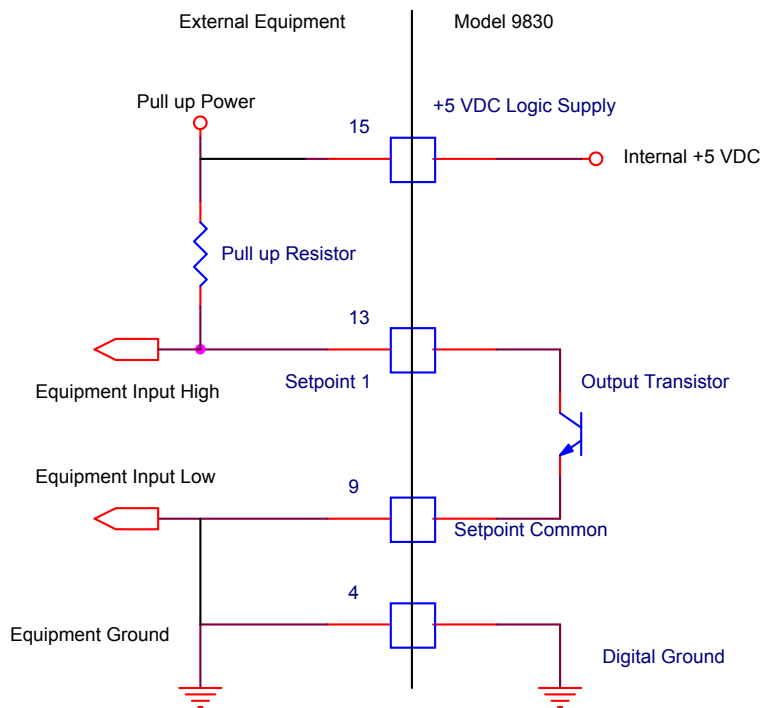
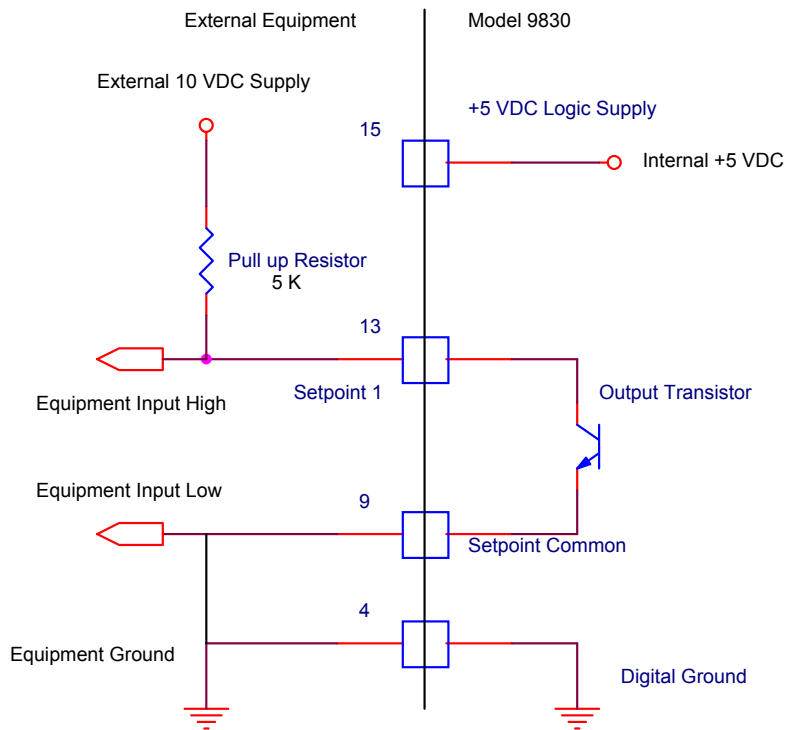

Figure 1

Figure 1 shows a typical installation with the dotted line from pin 15 showing the use of the 9830 internal +5 volt supply as the pull up power supply. The pull-up resistor must be chosen to limit the current through to < 10 mA (a value between 2.5 KΩ and 5 KΩ should be fine). If the internal +5 VDC supply is used, the current draw of all 4 set point outputs must be lower than 25 mA.

Note that the model 9830 pin 4 digital ground must be connected to a ground referenced to the user's equipment input, while pin 9, the output common, although usually connected to ground, can be connected to any voltage that is more negative than that of pin 15.



**Figure 2**

When using an external power supply as in figure 2 to provide power to the set point outputs, the value of the pull-up resistor in ohms should be between  $\text{SUPPLY VOLTAGE} / .01$  as the lowest value and  $\text{SUPPLY VOLTAGE} / .001$  as the highest.